

1 & 3 Meter Tower

CAT—1M—203R – RIGHT MOUNT – CAT—3M—203R

CAT—1M—203L – LEFT MOUNT – CAT—3M—203L

CAT—1M—203D – DUAL MOUNT – CAT—3M—203D

CAT—1M—203H – HEEL MOUNT – CAT—3M—203H

WARNING

CAUTION: DIVING BOARD AND TOWER COMBINATIONS MUST MEET THE ANSI/APSP/ICC-1 2014 STANDARD FOR PUBLIC SWIMMING POOLS. COMPLY WITH LOCAL GOVERNMENT REGULATIONS IF THEY EXCEED THE ANSI/APSP/ICC-1 2014 STANDARDS.

All diving boards and related equipment are manufactured for inground swimming pools ONLY. The S.R. Smith 1 & 3 Meter Towers are designed to be easily transported and installed. Follow all instructions carefully and inspect closely to assure proper and safe installations.

PROPER INSTALLATION CANNOT BE OVERSTRESSED,
AS AN IMPROPER INSTALLATION VOIDS S.R. SMITH'S WARRANTY.

IMPORTANT ASSEMBLY AND INSTALLATION INSTRUCTIONS -- PLEASE READ CAREFULLY --

**THIS STAND IS PRIMED ONLY. WE STRONGLY RECOMMEND A HIGH QUALITY
ACRYLIC URETHANE ENAMEL FOR A DURABLE FINISH.**



WORLD'S LARGEST MANUFACTURER OF
DIVING BOARDS, SLIDES &
STAINLESS STEEL RAIL PRODUCTS



American National Standards Institute



WESTERN SALES AND MANUFACTUREING PLANT
CORPORATE HEADQUARTERS
P.O. Box 400 . 1017 S.W. Berg Parkway
Canby, Oregon 97013
Phone (503) 266.2231 . FAX (503) 266.4334

The following completed assemblies have been show to demonstrate the overall installation dimension required for safe diving.

The following table provides the minimum dimension requirements for 1 & 3 METER TOWERS.

1 & 3 METER TOWERS CHART 1 RULE SHEET

Refer to Fig. 6.2.2 & 6.3.5

From ANSI/APSP/ICC-1 2014 STANDARD FOR PUBLIC SWIMMING POOLS

Model	Board A	Pool Type	Distance For Setting Front Bolt of Jig From Water's Edge B	Fulcrum Setting C+/-6"	Minimum Overhang	Max. Height of Board Above Water D
1 Meter	14'	VIII	36-5/16"	74"	4'-0"	39-3/8"
1 Meter	16'	VIII	60-5/16"	86"	4'-0"	39-3/8"
1 Meter	14'	IX	12-5/16"	74"	6'-0"	39-3/8"
1 Meter	16'	IX	36-5/16"	86"	6'-0"	39-3/8"
3 Meter	14'	IX	33-1/4"	74"	6'-0"	118-1/8"
3 Meter	16'	IX	57-1/4"	86"	6'-0"	118-1/8"

THE FULCRUM SETTING DIMENSION "C" IS MEASURED FROM CENTER OF MOUNTING HOLES TOWARDS TOE END OF BOARD.

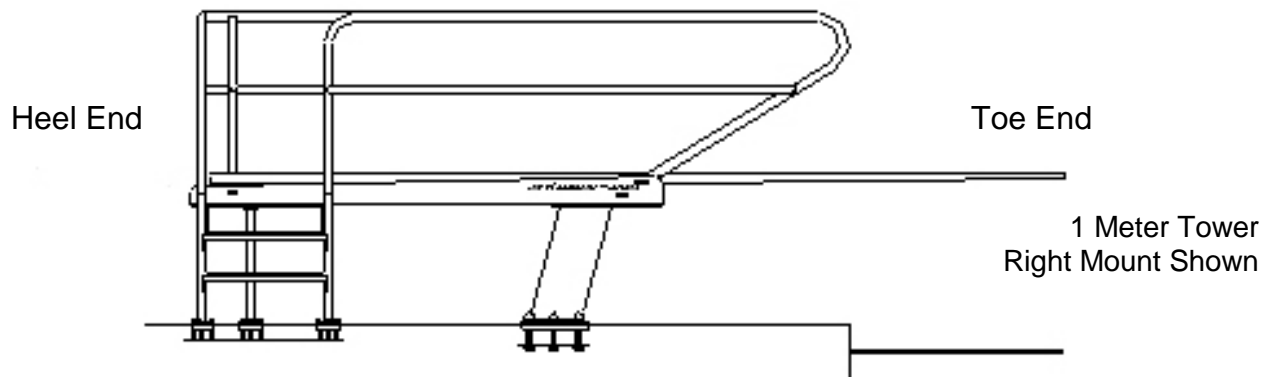

FIG. 1

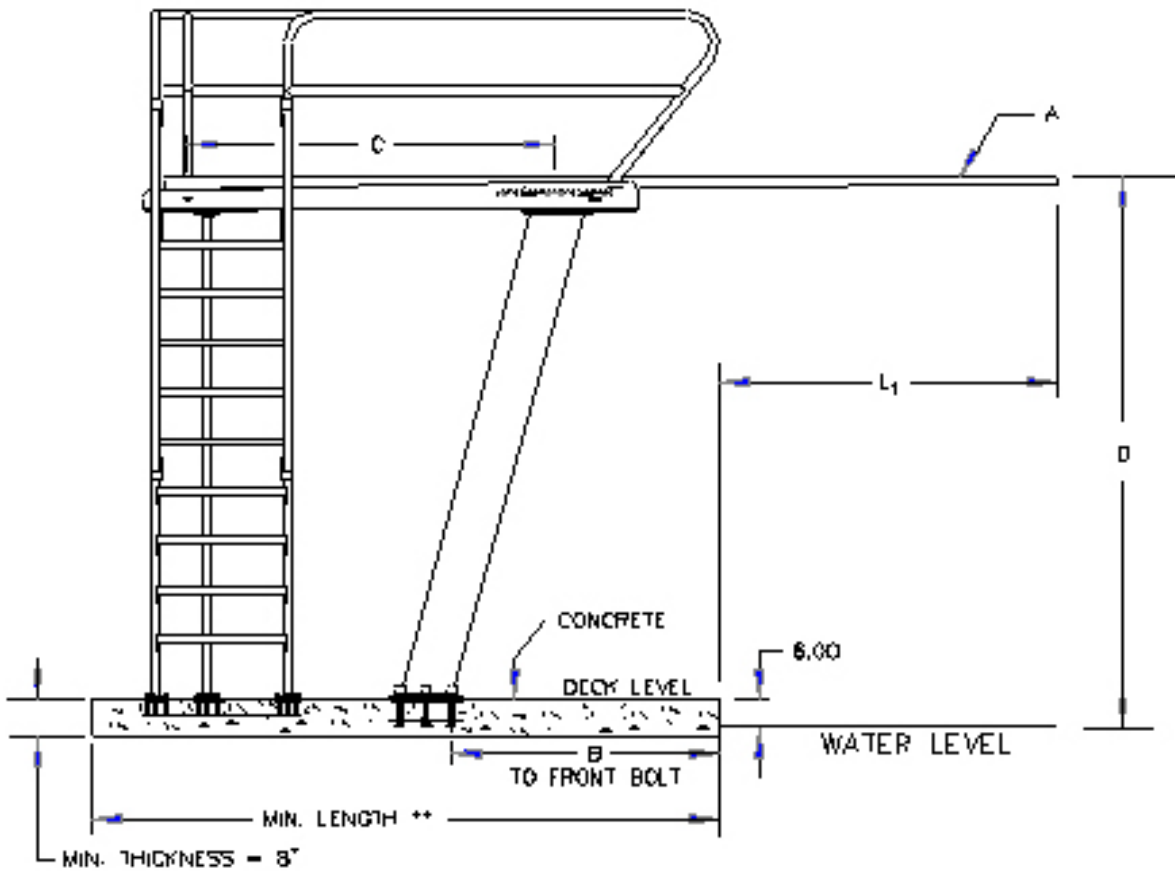

FIG. 2

3 Meter Tower
Right Mount Shown

**S.R. SMITH CAN NOT
GUARANTEE
CUSTOMER'S CONCRETE
OR THICKNESS**

RECOMMEND compression strength of concrete to be 3500 psi or greater.

*ANSI/APSP/ICC-1 refers to Heel as Butt and Toe as Tip end of board.

** MIN. LENGTH: Minimum thickness of concrete is 8"

Minimum concrete length is "MIN LENGTH" plus 15"

Minimum concrete width for 1 Meter Tower is 80"

Minimum concrete width for 3 Meter Tower is 121"

INSTALLATION INSTRUCTIONS FOR METER TOWER

CAUTION: DIVING BOARD AND TOWER COMBINATION
MUST MEET THE ANSI/APSP/ICC-1 2014 STANDARD FOUND ON
PAGES 13 THROUGH 19 OF THIS MANUAL. COMPLY WITH THE
LOCAL GOVERNMENT REGULATIONS IF THEY EXCEED THE
ANSI/APSP/ICC-1 2014 STANDARD.

It is CRITICAL that the jigs are located according to the FIGURES in the following pages.
The top surface of the jigs must be level and flush with the concrete surface.
Keep bolt threads and top surface of jig plates clean of concrete.
Let concrete cure before installing Meter Tower.

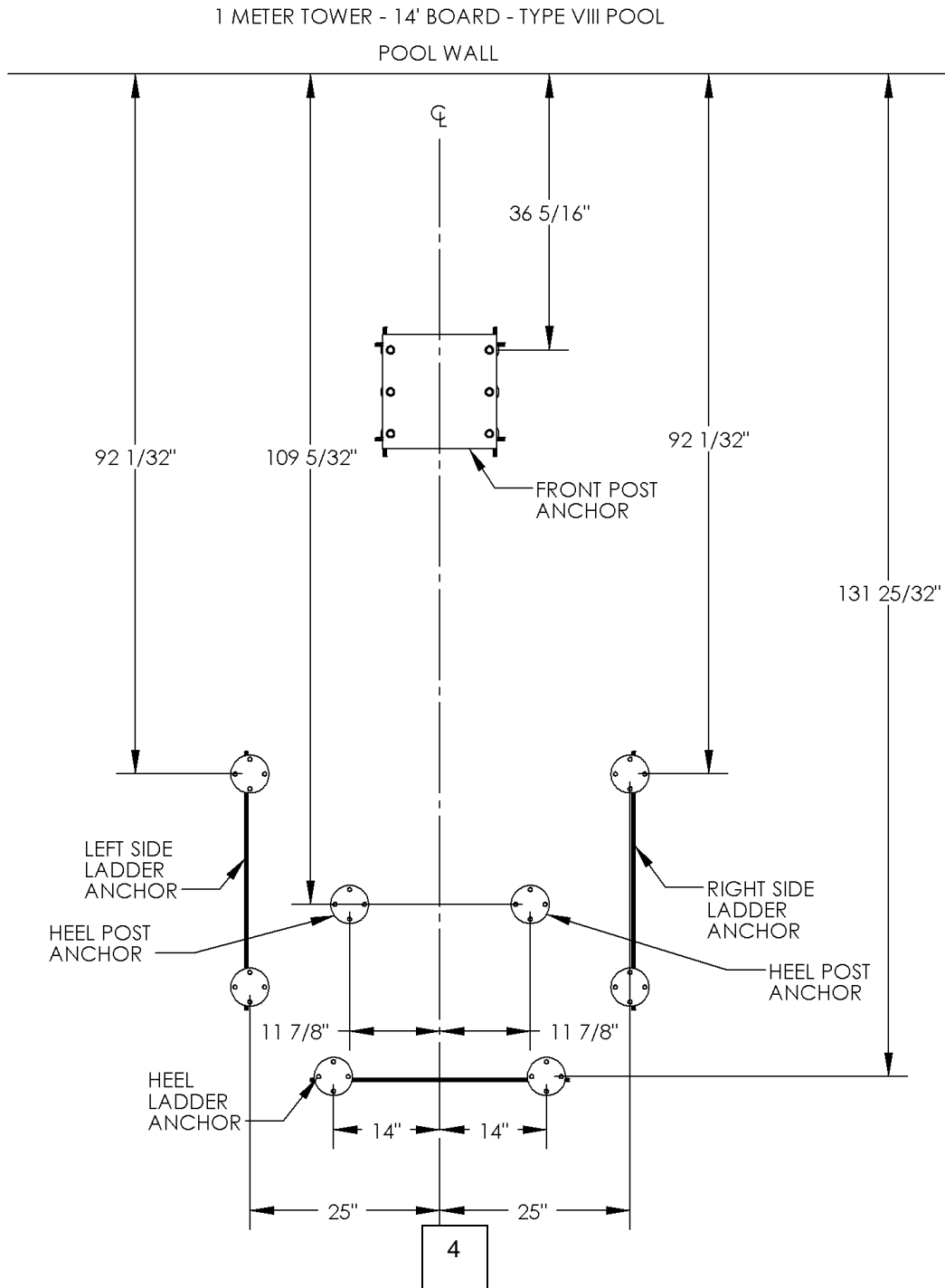

CAUTION: DIVING BOARD AND TOWER COMBINATION
 MUST MEET THE ANSI/APSP/ICC-1 2014 STANDARD FOUND ON
 PAGES 13 THROUGH 19 OF THIS MANUAL. COMPLY WITH THE
 LOCAL GOVERNMENT REGULATIONS IF THEY EXCEED THE
 ANSI/APSP/ICC-1 2014 STANDARD.

It is CRITICAL that the jigs are located according to the FIGURES in the following pages.
 The top surface of the jigs must be level and flush with the concrete surface.
 Keep bolt threads and top surface of jig plates clean of concrete.
 Let concrete cure before installing Meter Tower.

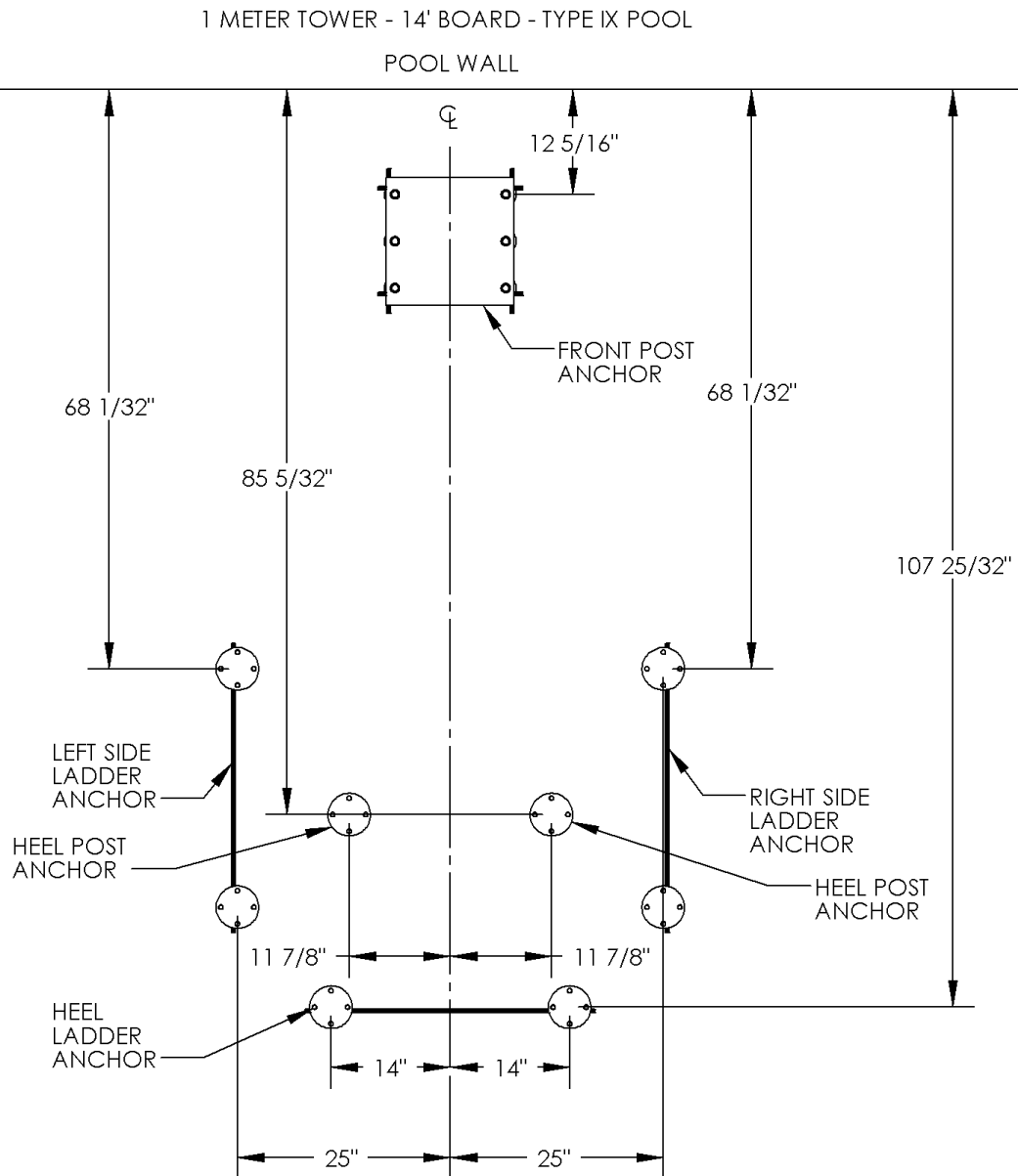

CAUTION: DIVING BOARD AND TOWER COMBINATION
 MUST MEET THE ANSI/APSP/ICC-1 2014 STANDARD FOUND ON
 PAGES 13 THROUGH 19 OF THIS MANUAL. COMPLY WITH THE
 LOCAL GOVERNMENT REGULATIONS IF THEY EXCEED THE
 ANSI/APSP/ICC-1 2014 STANDARD.

It is CRITICAL that the jigs are located according to the FIGURES in the following pages.
 The top surface of the jigs must be level and flush with the concrete surface.
 Keep bolt threads and top surface of jig plates clean of concrete.
 Let concrete cure before installing Meter Tower.

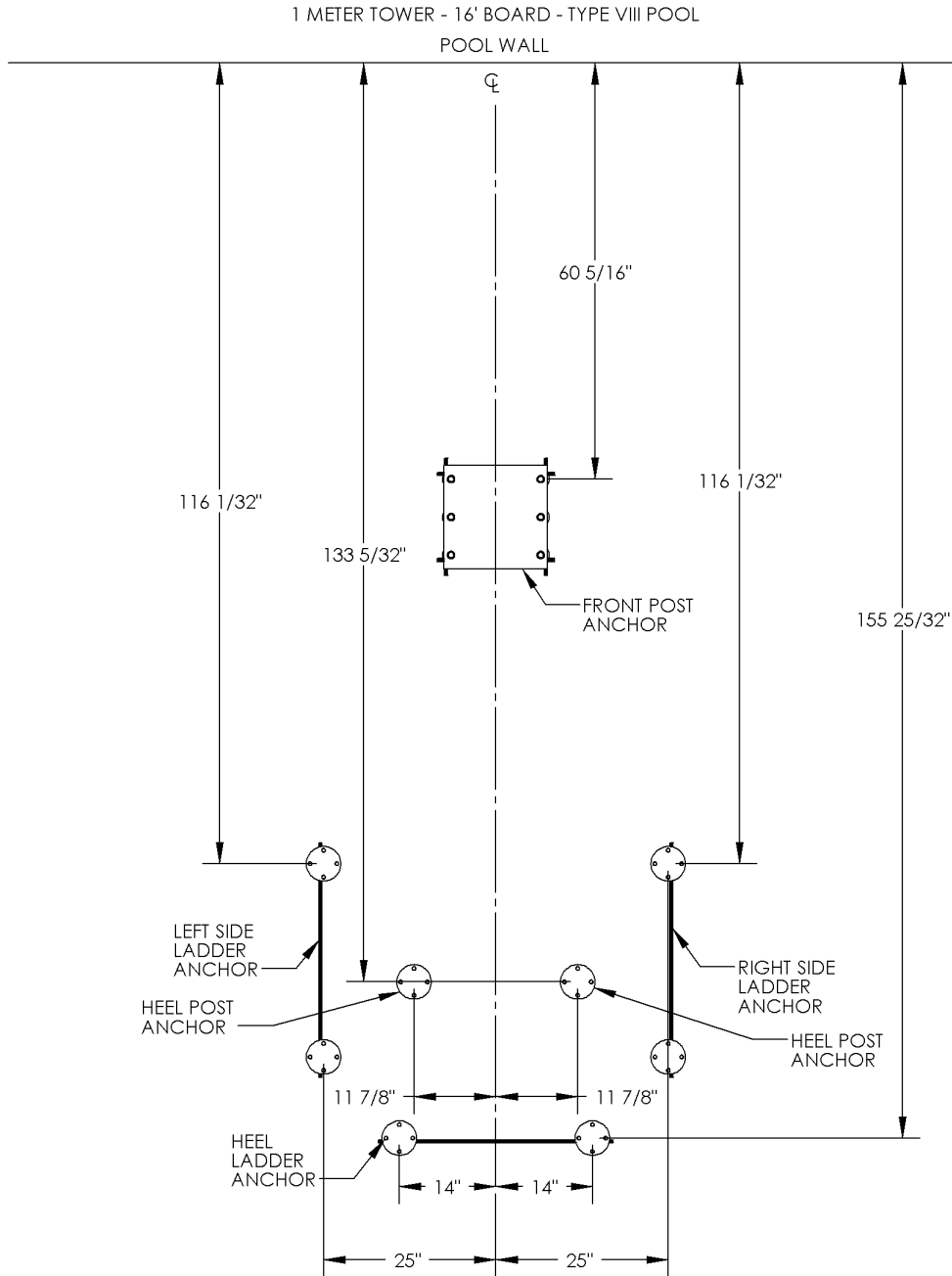

CAUTION: DIVING BOARD AND TOWER COMBINATION MUST MEET THE ANSI/APSP/ICC-1 2014 STANDARD FOUND ON PAGES 13 THROUGH 19 OF THIS MANUAL. COMPLY WITH THE LOCAL GOVERNMENT REGULATIONS IF THEY EXCEED THE ANSI/APSP/ICC-1 2014 STANDARD.

It is **CRITICAL** that the jigs are located according to the **FIGURES** in the following pages. The top surface of the jigs must be level and flush with the concrete surface. Keep bolt threads and top surface of jig plates clean of concrete. Let concrete cure before installing Meter Tower.

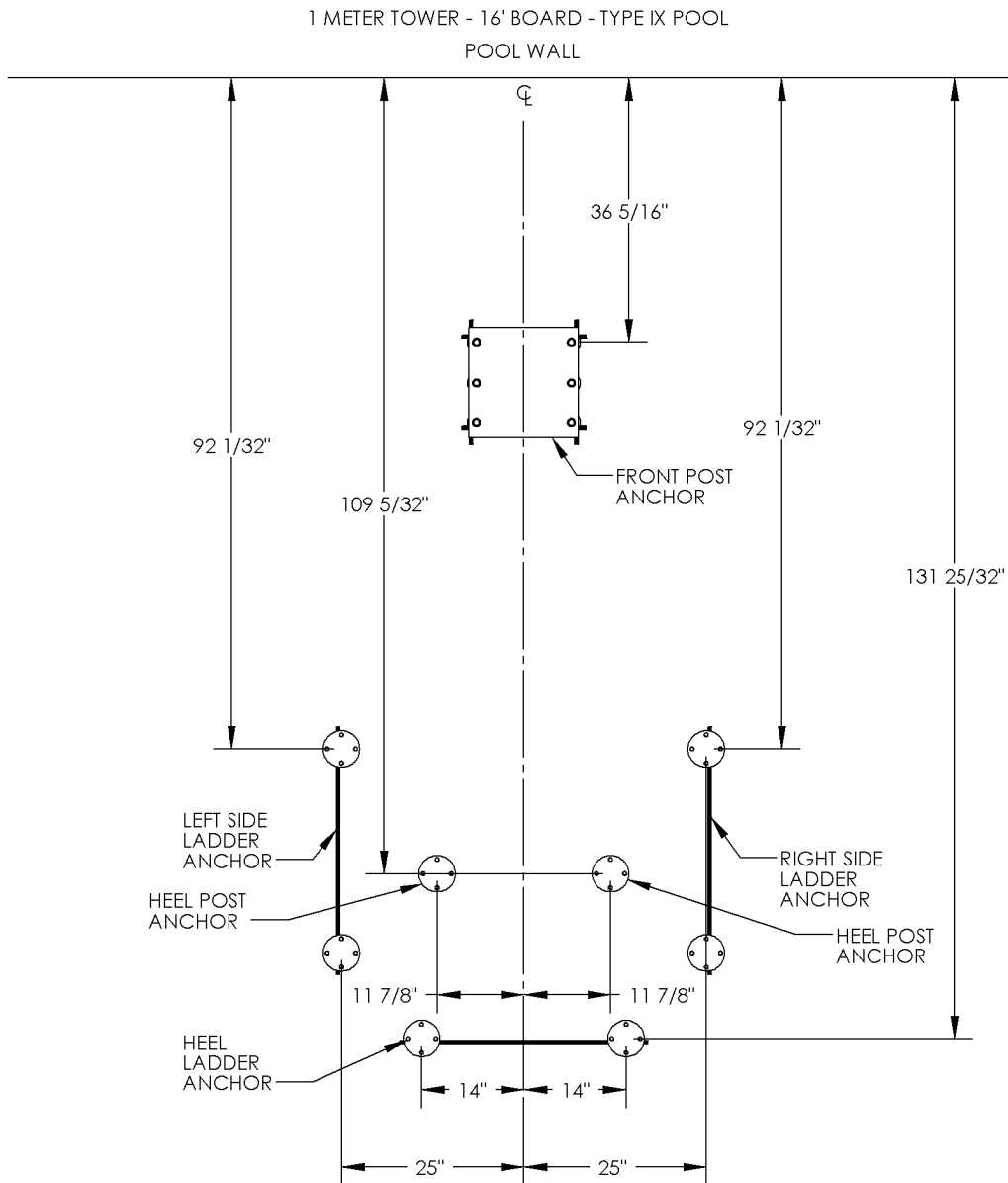

CAUTION: DIVING BOARD AND TOWER COMBINATION MUST MEET THE ANSI/APSP/ICC-1 2014 STANDARD FOUND ON PAGES 13 THROUGH 19 OF THIS MANUAL. COMPLY WITH THE LOCAL GOVERNMENT REGULATIONS IF THEY EXCEED THE ANSI/APSP/ICC-1 2014 STANDARD.

It is **CRITICAL** that the jigs are located according to the **FIGURES** in the following pages. The top surface of the jigs must be level and flush with the concrete surface. Keep bolt threads and top surface of jig plates clean of concrete. Let concrete cure before installing Meter Tower.

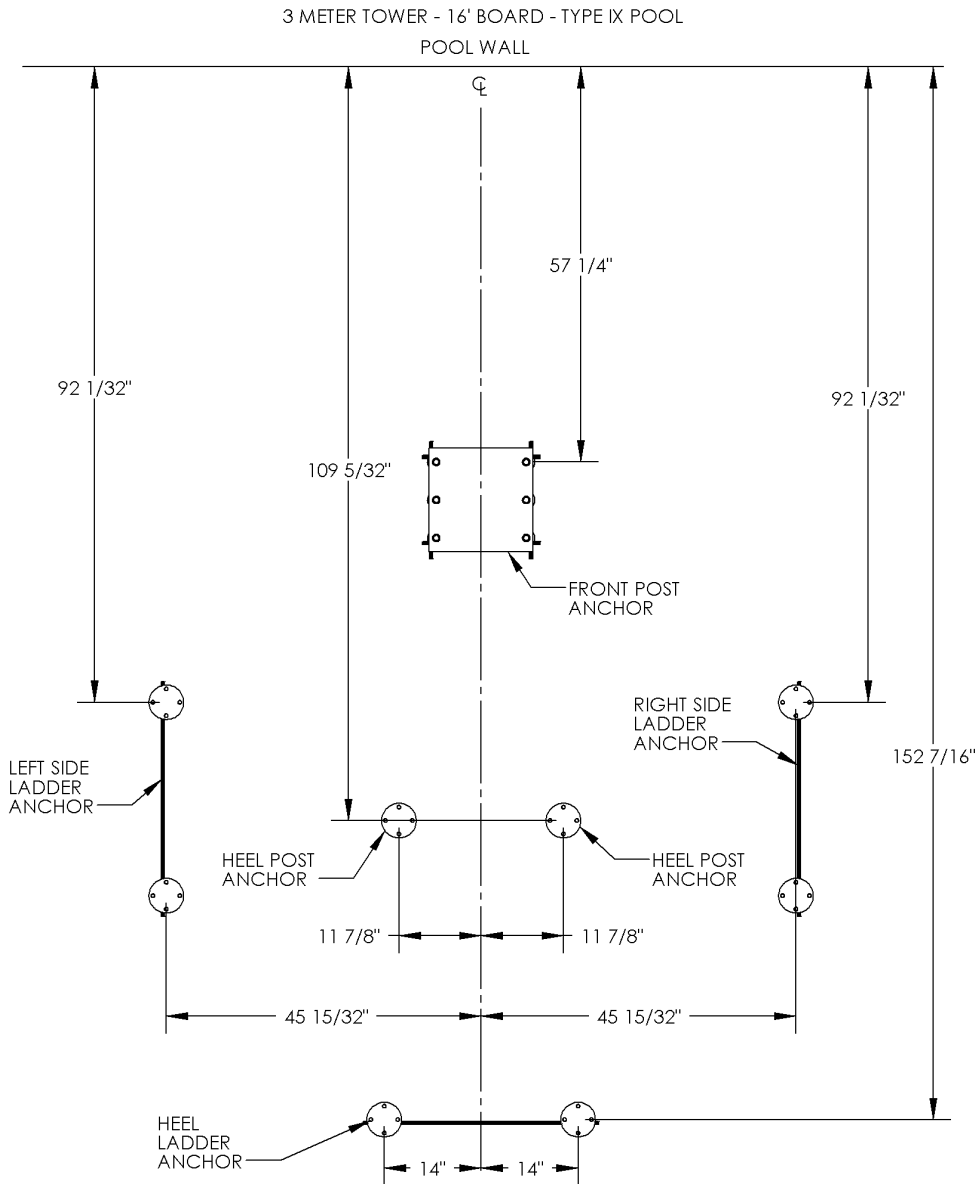

ANCHORING METHODS

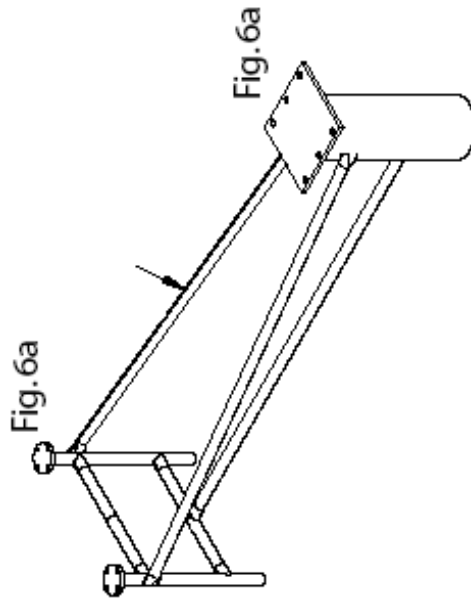

4f



Anchor Method 1

Anchor Method 1 is for 1 and 3 Meter Tower, Heel Mount Tower Anchor Jig Style Assembly and is detailed in Fig. 6a and Fig 6b.

Anchor Method 2

Anchor Method 2 is for 1 and 3 Meter Tower, Cage Style Anchor Assembly and is detailed in Fig. 7a and Fig. 7b.

ANCHOR METHOD 1

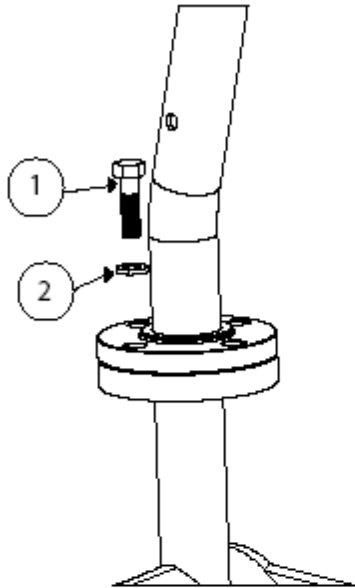
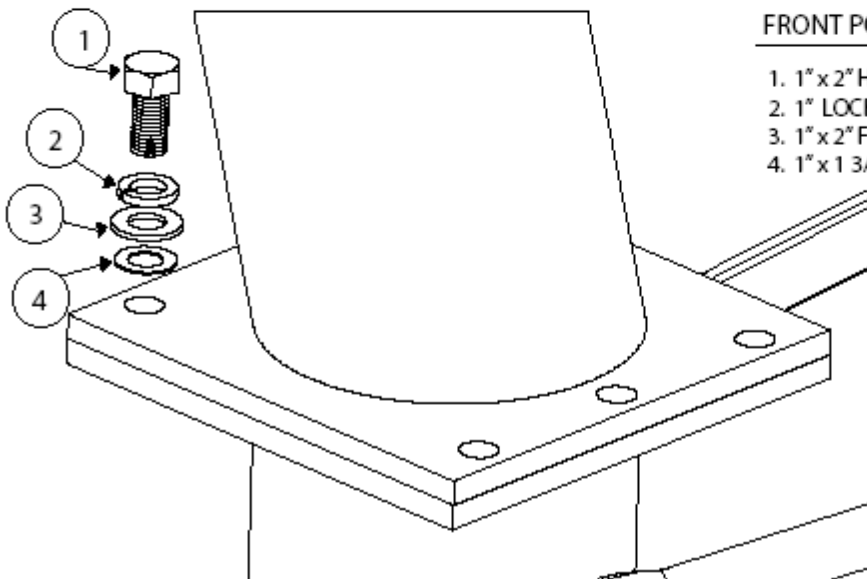

FIG. 6a

REAR POST /LADDER ANCHORING

1. 1/2" x 1 3/4" HEX HEAD BOLT S/S
2. 1/2" LOCK WASHER S/S

FIG. 6b



FRONT POST ANCHORING

1. 1" x 2" HEX HEAD BOLT C/S
2. 1" LOCK WASHER C/S
3. 1" x 2" FLAT WASHER C/S
4. 1" x 1 3/4" NYLON WASHER

ASSEMBLING METER TOWER

2. Assemble stainless steel Treads to Ladder Posts with hardware according to Fig. 4. Hand tighten only.

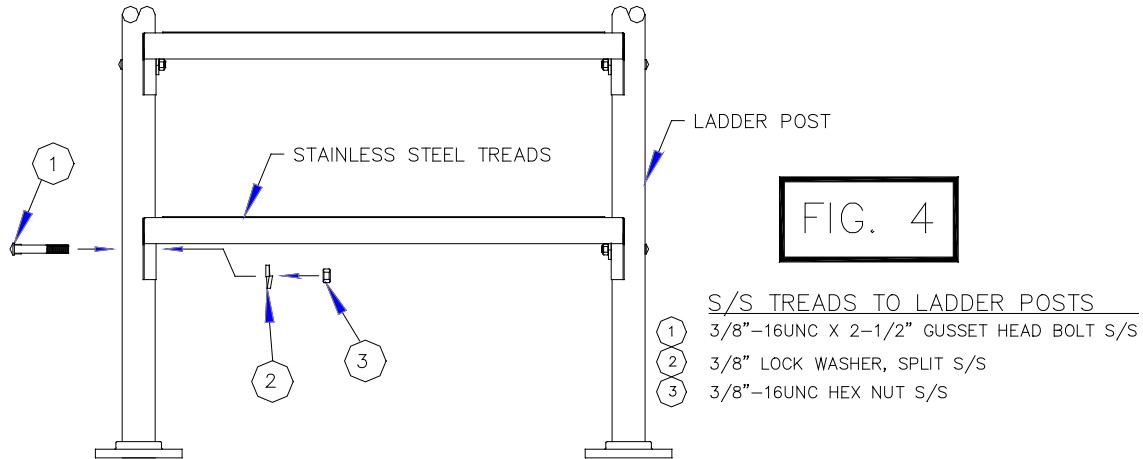

3. (Dual Mount Tower Only) Assemble the Dual Mount Tray Handrail with hardware to the two Ladder Assemblies according to Fig. 5. Hand tighten only.

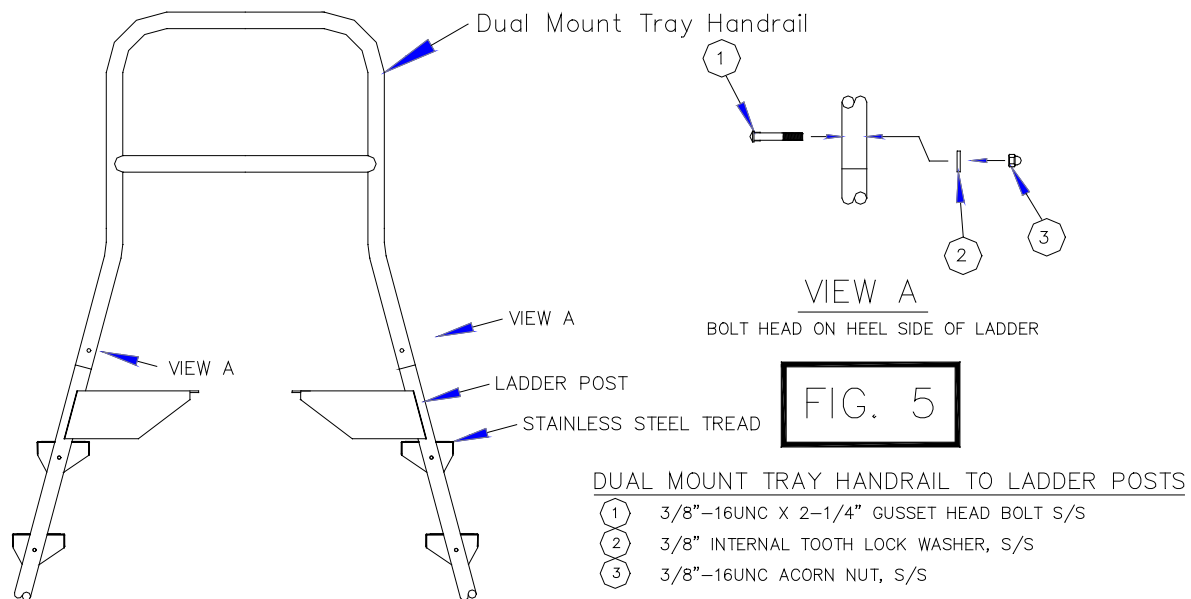

4. Install Front Post Assembly with hardware to jig according to Fig. 6. Ensure that rubber gasket is in place. Tighten hardware between 40 and 50 ft. lbs.

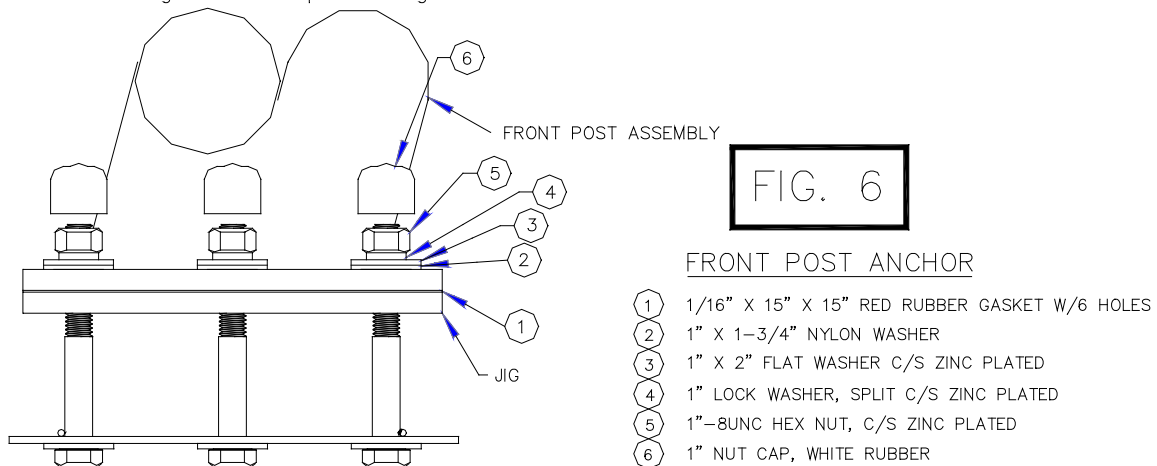

5. Install Ladder Assembly and Heel Post Assembly with hardware to respective jigs according to Fig. 7. Make sure gaskets are in place. Hand tighten only.

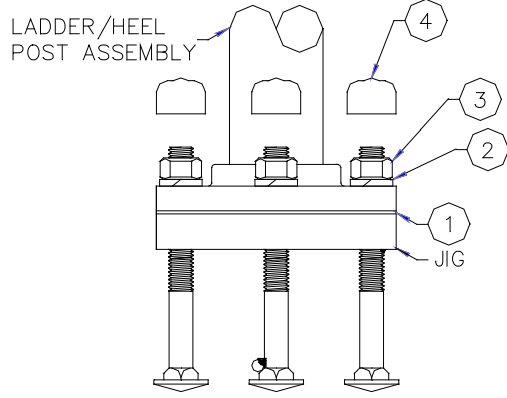

FIG. 7

LADDER & POST ANCHORS

- 1 1/16" X 5" DIA. RED RUBBER GASKET
- 2 1/2" LOCK WASHER, SPLIT C/S ZINC PLATED
- 3 1/2"-13UNC HEX NUT, C/S ZINC PLATED
- 4 1/2" PLASTIC NUT CAP

6. Place gaskets on top of the Ladder Brackets, Front Post Plate and Heel Post Flange. Place Tray on these gaskets and align holes in Tray with the holes in the Front Post Plate. Assemble with hardware according to Fig. 8. Align holes in Ladder Brackets and Heel Post Flange with the holes in the Tray. Assemble with hardware according to Fig. 9 and 10. See step 7 for tightening schedule.

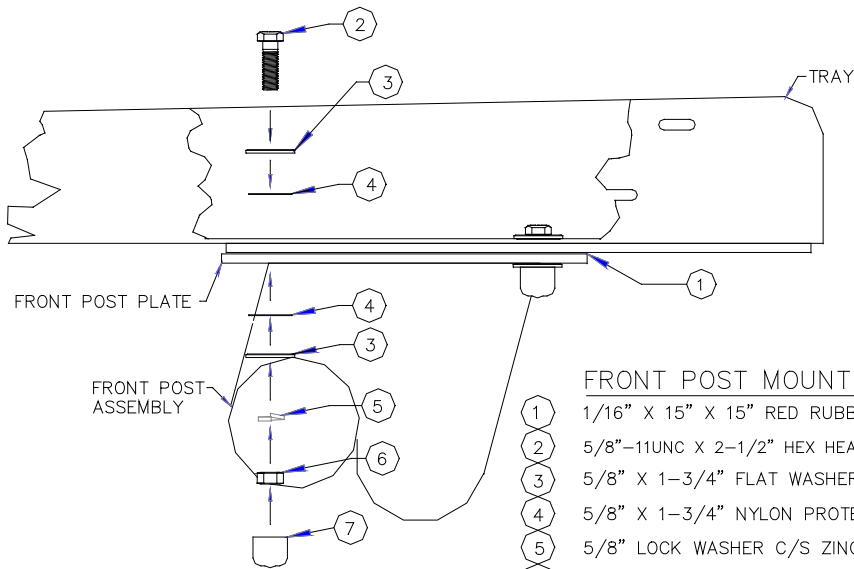

FIG. 8

FRONT POST MOUNT

- 1 1/16" X 15" X 15" RED RUBBER GASKET W/ 4 HOLES
- 2 5/8"-11UNC X 2-1/2" HEX HEAD BOLT GRADE 5 C/S ZINC PLATED
- 3 5/8" X 1-3/4" FLAT WASHER C/S ZINC PLATED
- 4 5/8" X 1-3/4" NYLON PROTECTIVE WASHER
- 5 5/8" LOCK WASHER C/S ZINC PLATED
- 6 5/8"-11UNC HEX NUT C/S ZINC PLATED
- 7 5/8" NUT CAP, WHITE RUBBER

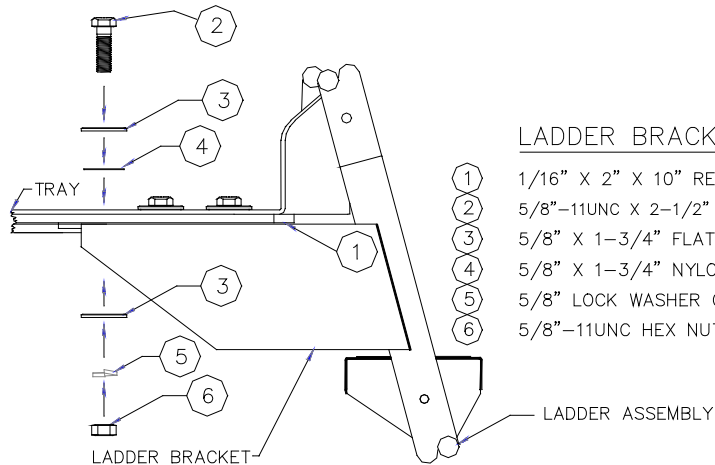

FIG. 9

LADDER BRACKET MOUNT

- 1 1/16" X 2" X 10" RED RUBBER GASKET
- 2 5/8"-11UNC X 2-1/2" HEX HEAD BOLT GRADE 5 C/S ZINC PLATED
- 3 5/8" X 1-3/4" FLAT WASHER C/S ZINC PLATED
- 4 5/8" X 1-3/4" NYLON PROTECTIVE WASHER
- 5 5/8" LOCK WASHER C/S ZINC PLATED
- 6 5/8"-11UNC HEX NUT C/S ZINC PLATED

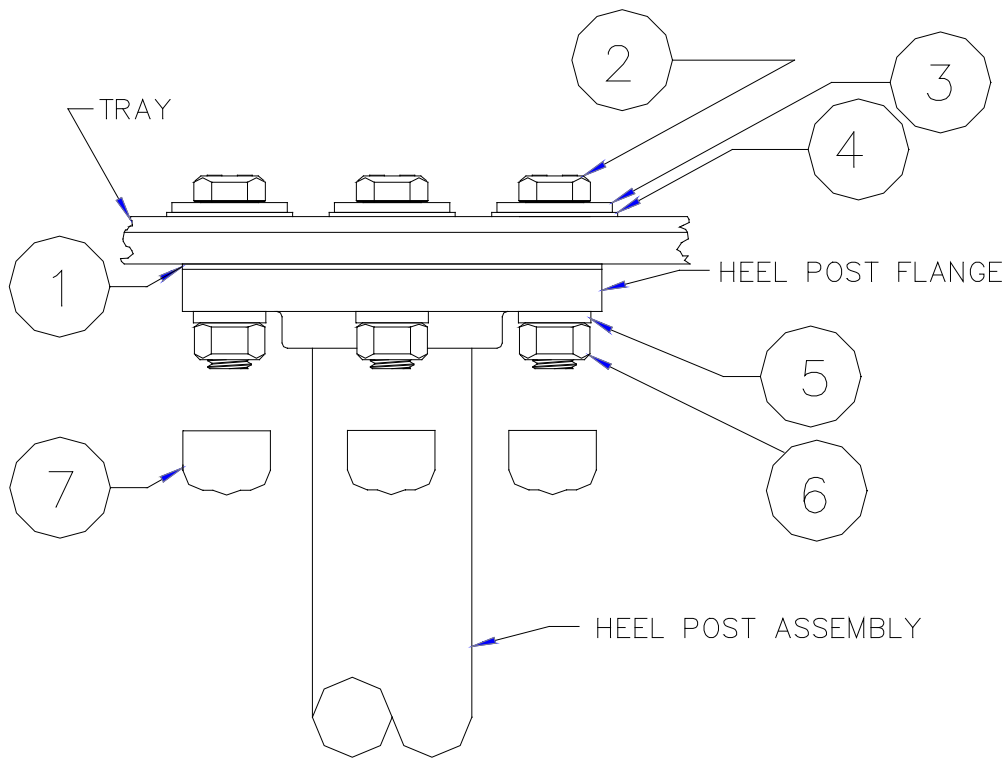

FIG. 10

HEEL POST MOUNT

- ① 1/16" X 5" DIA. RED RUBBER GASKET
- ② 1/2"-13UNC X 2" HEX HEAD CAP SCREW, C/S ZINC PLATED
- ③ 1/2" X 1-3/8" FLAT WASHER, C/S ZINC PLATED
- ④ 1/2" X 1-1/2" ROUND NYLON WASHER
- ⑤ 1/2" LOCK WASHER, SPLIT C/S ZINC PLATED
- ⑥ 1/2"-13UNC HEX NUT, C/S ZINC PLATED
- ⑦ 1/2" PLASTIC NUT CAP

7. Tighten hardware connecting Front Post Assembly, Ladder Brackets and Heel Post Assembly to the Tray between 40 and 50 ft. lbs. Then tighten hardware connecting Ladder Assembly and Heel Post Assembly to jigs between 40 and 50 ft. lbs. Now tighten hardware connecting Treads and Dual Tray Handrail (if applicable) to Ladder Posts between 15 and 20 ft. lbs. Do not over tighten.

8. Install Tray Handrails to Tray and Ladder Assembly according to Fig. 11 using hardware tightened between 15 and 20 ft. lbs. Do not over tighten.

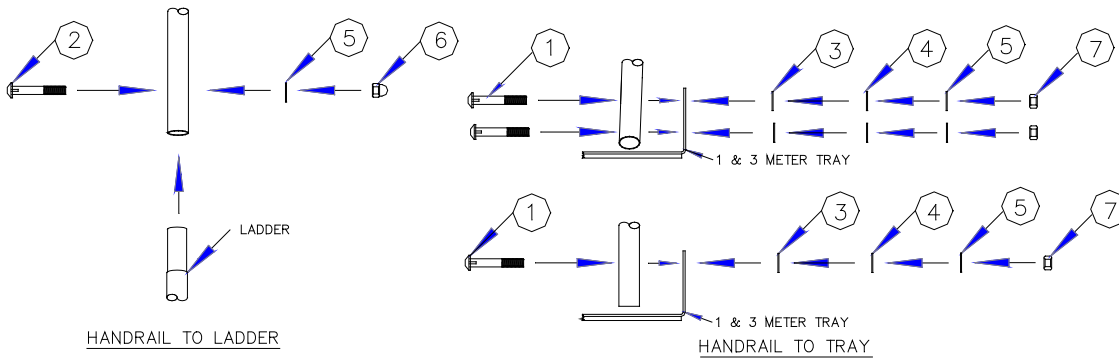

FIG. 11

TRAY HANDRAIL TO LADDER AND TRAY

- ① 3/8"-16UNC X 2-1/2" GUSSET HEAD BOLT, S/S
- ② 3/8"-16UNC X 2-1/4" GUSSET HEAD BOLT, S/S
- ③ 3/8" X 7/8" NYLON PROTECTIVE WASHER
- ④ 3/8" X 7/8" FLAT WASHER, S/S
- ⑤ 3/8" INTERNAL TOOTH LOCK WASHER, S/S
- ⑥ 3/8"-16UNC ACORN NUT, S/S
- ⑦ 3/8"-16UNC HEX NUT, S/S

9. (3 Meter Tower Only) Snap Ladder Handrail Assembly onto Ladder Posts and Tray Handrails as shown in Fig. 12. Drill 7/16" diameter holes through existing holes in Ladder Handrail Brackets through the Ladder Posts and Tray Handrails. Grind down any sharp edges or burrs. Assemble with hardware and tighten between 15 and 20 ft. lbs. Do not over tighten.

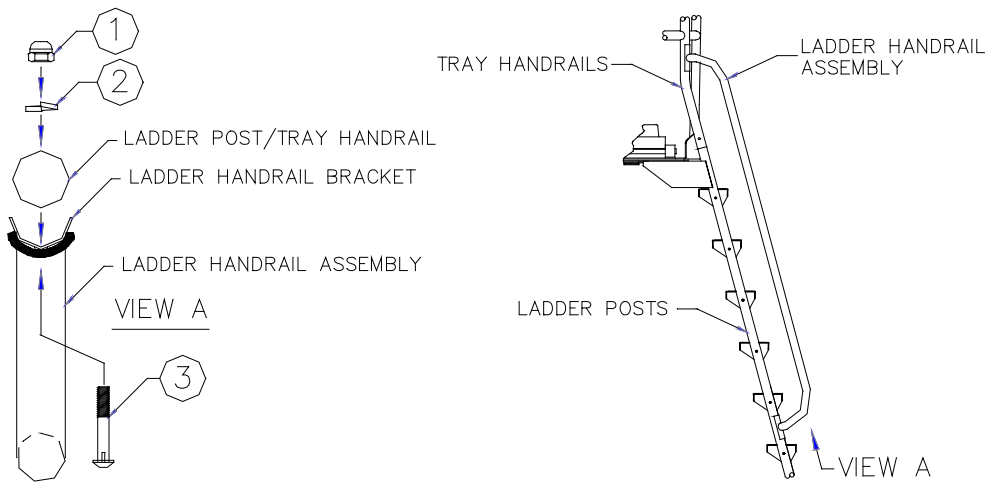

FIG. 12

LADDER HANDRAIL TO LADDER POSTS/TRAY HANDRAIL

- ① 3/8"-16UNC ACORN NUT S/S
- ② 3/8" LOCK WASHER, SPLIT S/S
- ③ 3/8"-16UNC X 2-1/2" GUSSET HEAD BOLT S/S

10. Assemble Tie Down Assembly to Tray according to Fig. 13 using hardware tightened between 40 and 50 ft. lbs. Do not over tighten.

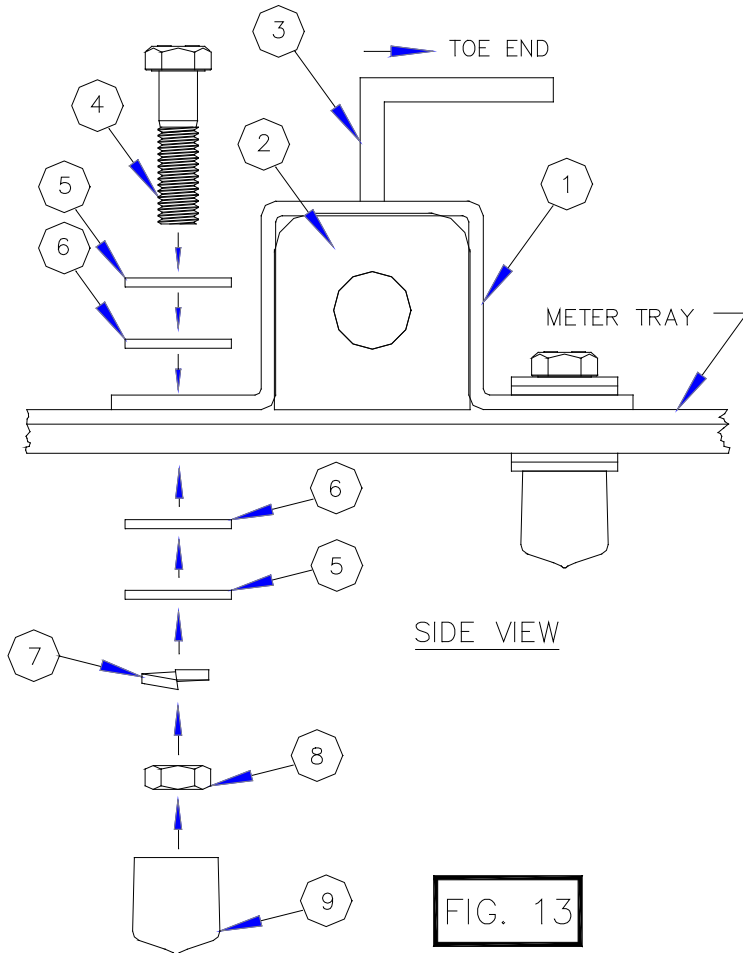
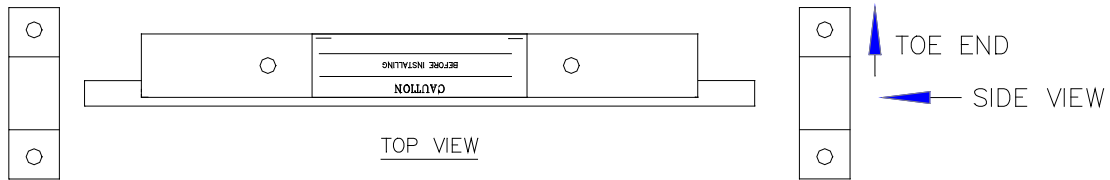

FIG. 13

TIE DOWN ASSEMBLY

- 1 TIE-DOWN STRAP (PRIMED)
- 2 URETHANE BLOCK
- 3 TIE-DOWN ANGLE ASSY'
- 4 1/2"-13UNC X 2" HEX HEAD CAP SCREW, C/S ZINC PLATED
- 5 1/2" X 1-3/8" FLAT WASHER, C/S ZINC PLATED
- 6 1/2" X 1-1/2" ROUND NYLON WASHER
- 7 1/2" LOCK WASHER, SPLIT C/S ZINC PLATED
- 8 1/2"-13UNC HEX NUT, C/S ZINC PLATED
- 9 1/2" PLASTIC NUT CAP

12. Stick the Fulcrum Adjustment Label over the Gear Rack Cover as shown in Fig. 15. Insert the Ratchet Handle Assembly into the Ratchet Housing and tap roll pin through the holes to secure.

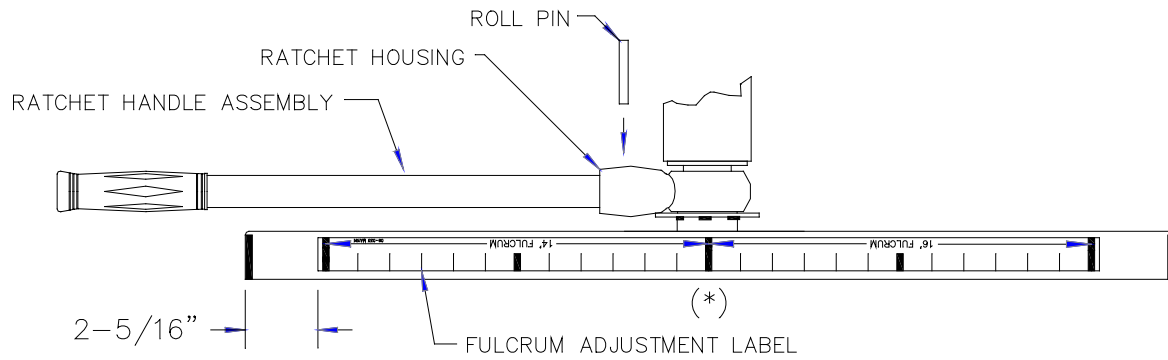

FIG. 15

13. Stick the Tray Fulcrum Adjustment Label on the right outside wall of the Tray as shown in Fig. 16 with the centerline of the Tray Fulcrum Adjustment Label (*) aligned with the centerline of the Fulcrum Adjustment label (*) as indicated in Fig. 15.

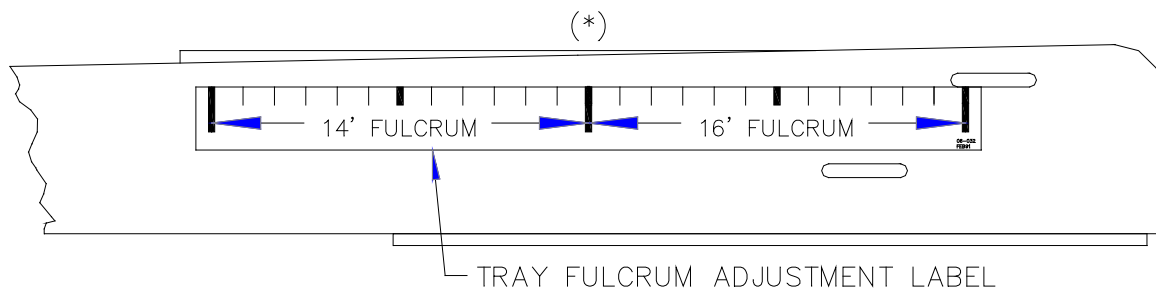

FIG. 16

INSTALLATION OF THE QUICK ADJUSTABLE FULCRUM

11.

Place the Gear Rack Assembly over the line of eight 1/2" diameter holes on the left side of the Tray. Use the hole closest to the toe end of the Tray for S.R. Smith's 14' and 16' Commercial Diving Boards. Secure the Gear Rack Assembly according to Fig. 14 and hand tighten only. Place the other Gear Rack Assembly over the right side holes with the Fulcrum Axle Assembly inbetween. Make sure the gears mesh with and are perpendicular to the gear rack and that the Ratchet Housing is on the right side. Secure the Gear Rack Assembly to the Tray using hardware tightened between 20 and 30 ft. lbs. Do not over tighten.

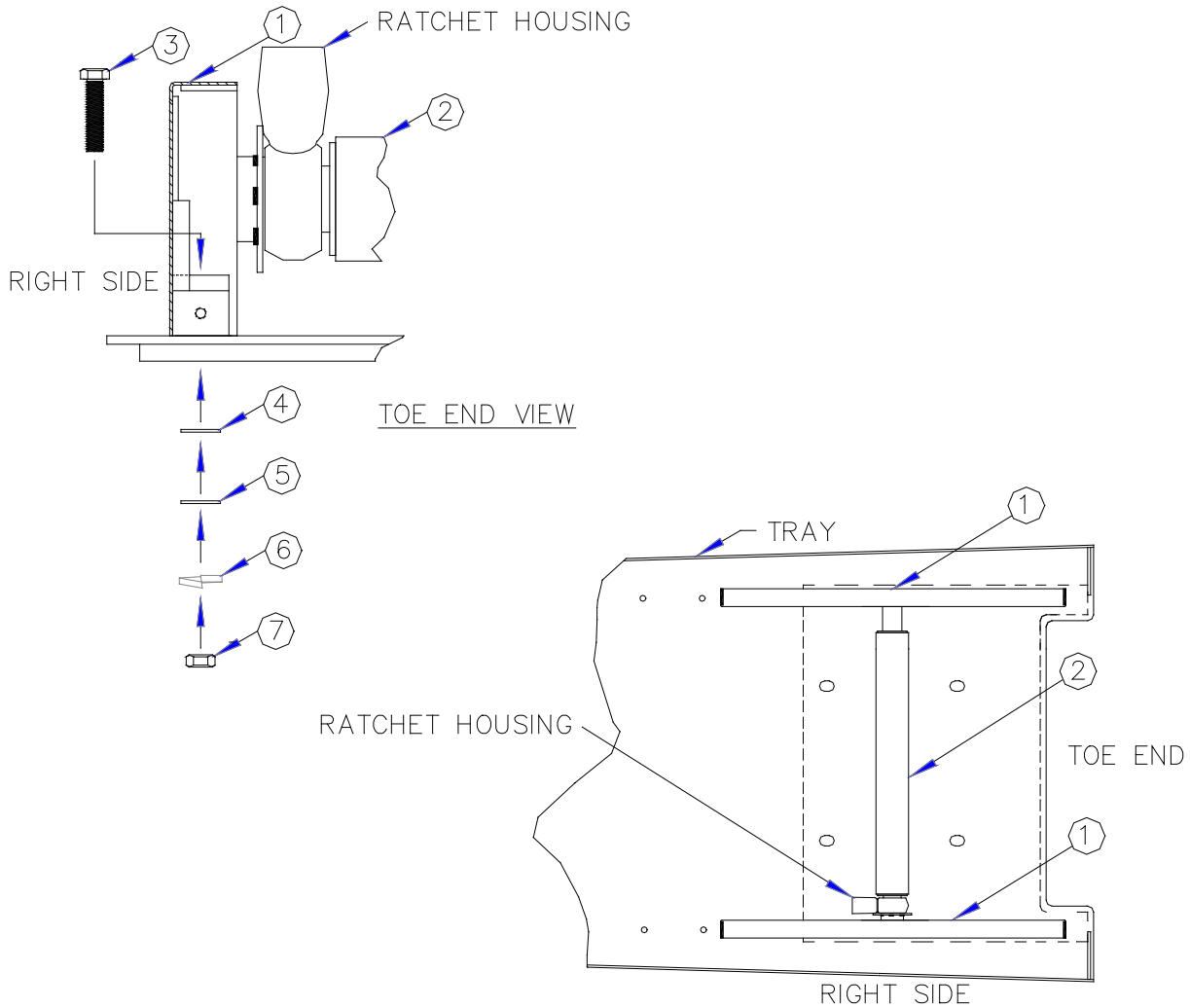

FIG. 14

QUICK ADJUSTABLE FULCRUM

- ① GEAR RACK ASSEMBLY
- ② FULCRUM AXLE ASSEMBLY
- ③ 3/8"-16UNC X 2" HEX HEAD CAP SCREW S/S
- ④ 3/8" X 7/8" NYLON PROTECTIVE WASHER
- ⑤ 3/8" X 7/8" FLAT WASHER S/S
- ⑥ 3/8" LOCK WASHER, SPLIT S/S
- ⑦ 3/8"-16UNC HEX NUT S/S

INSTALL DIVING BOARD

14. Secure the Diving Board to the Tie Down Assembly according to Fig. 17 and tighten hardware between 20 and 25 ft. lbs. Do not over tighten.

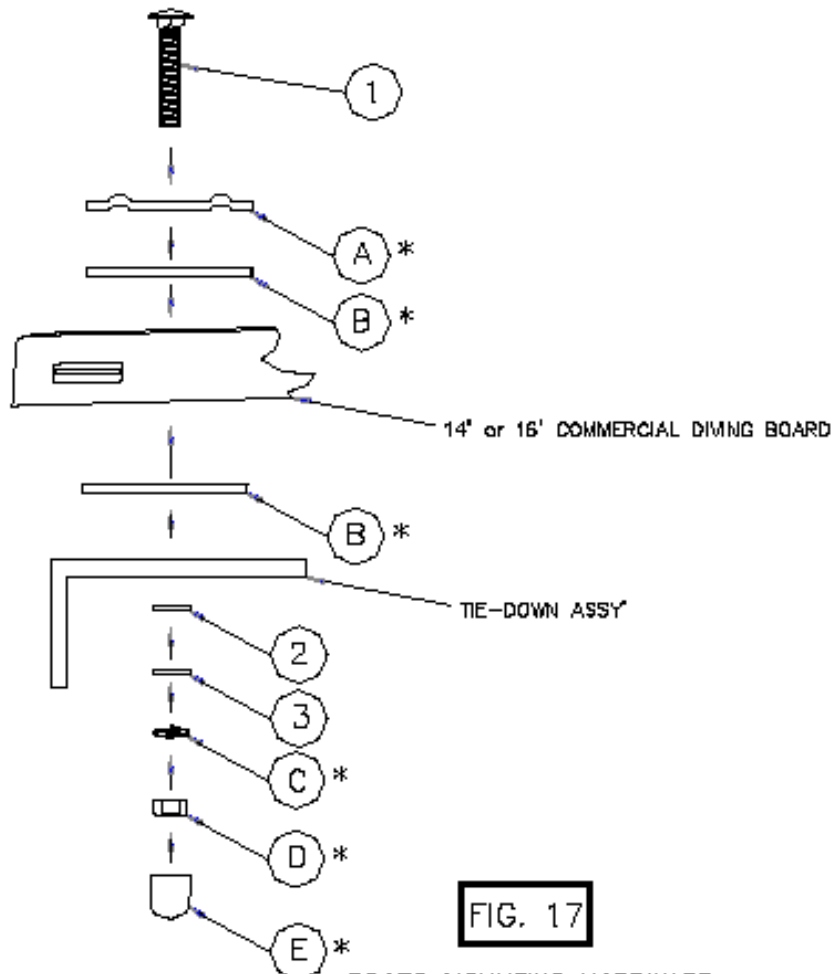

FIG. 17

BOARD MOUNTING HARDWARE

(INCLUDED IN 1 & 3 METER TOWER HARDWARE KIT)

- ① 1/2" X 4" CARRIAGE BOLT GRADE 5 C/S ZINC PLATED
- ② 1/2" X 1-1/2" ROUND NYLON WASHER
- ③ 1/2" X 1-3/8" FLAT WASHER C/S ZINC PLATED

* HARDWARE LOCATED IN THE 20" COMMERCIAL MOUNTING KIT
Included with 14' and 18' Commercial Diving Boards.

- Ⓐ 20" TOP MOUNTING PLATE
- Ⓑ 20" RUBBER MOUNTING PAD
- Ⓒ 1/2" LOCK WASHER C/S ZINC PLATED
- Ⓓ 1/2" HEX NUT C/S ZINC PLATED
- Ⓔ 1/2" PLASTIC NUT CAP

16. Check to ensure compliance with ANSI/NSPI-1 2003 STANDARD FOR PUBLIC SWIMMING POOLS. Adjust the fulcrum according to Chart 1 Rule Sheet on page 2.

17. ONLY ONE PERSON ON DIVING BOARD AT A TIME, WITH A MAXIMUM WEIGHT OF 250 LBS.

**SELECTED SECTIONS EXTRACTED FROM
ANSI/APSP/ICC-1 2014
AMERICAN NATIONAL STANDARD FOR PUBLIC SWIMMING POOLS**

Standard for Public Swimming Pools

1 Scope

1.1 Public swimming pools. This standard covers public swimming pools to be used for swimming, bathing, competitive activities, or recreational activities and operated by an owner, lessee, operator, licensee, or concessionaire, regardless of whether a fee is charged for use.

1.1.1 Public swimming pools covered by this standard. Public swimming pools covered by this standard include the following:

1.1.1.1 Class A pools. Any pool intended for use for accredited competitive aquatic events such as Federation Internationale De Natation (FINA), USA Swimming, USA Diving, USA Synchronized Swimming, USA Water Polo, National Collegiate Athletic Association (NCAA), National Federation of State High School Associations (NFHS). The use of the pool is not limited to competitive events.)

1.1.1.2 Class B pools. Any pool, not otherwise classified, intended for public recreational use

1.1.1.3 Class C pools. Semi-public pools. Any pool operated solely for and in conjunction with lodgings such as hotels, motels, apartments, condominiums.)

1.1.1.4 Class F pools. Class F pools are wading pools and are covered within the scope of this standard as set forth in Sections 6.9 and 8.4.2 and as noted in other sections of the standard.

1.2 Variation in design. This standard provides specifications for the design, equipment, operation, warning signs, installation, sanitation, new construction, and renovation of public swimming pools. This standard permits variations in equipment, materials, and design to accommodate special needs and considerations and advances in technology and to provide the required quality, strength, durability, and safety for the intended use.

1.3 Renovation. Renovation does not include ordinary maintenance. Only those items that are renovated shall adhere to this standard. (See Section 3 Definitions)

2 Normative references

The following standards contain provisions that, through reference in this text, constitute provisions of this American National Standard. At the time of publication, the editions indicated were valid. All standards are subject to revision, and parties to agreements based on this American National Standard are encouraged to investigate the possibility of applying the most recent editions of the standards indicated at right.

Americans with Disabilities Act (ADA) Accessibility guidelines for buildings and facilities; recreation facilities 1

ACI 302.1 R-04 (2004), Guide for concrete floor and slab construction 2

ANSI/APSP-2 1999 Standard for Public Spas 3

ANSI/NSF 50 (2012), Circulation system components and related materials for swimming pools, spas/hot tubs 4

ANSI/NSF 14 (2012), Plastics piping system components and related materials 5

ANSI/NEMA-MG1-2007, Motors and generators 6

ANSI/APSP/ICC-7 2013 Standard for Suction Entrapment Avoidance in Swimming Pools, Wading Pools, Spas, Hot Tubs, and Catch Basins 7

ANSI/APSP-16 2011 Standard for Suction Fittings for Use in Swimming Pools, Wading Pools, Spas, and Hot Tubs 8

ANSI/NFPA 70: National Electrical Code, 2014 9

ANSI Z21.56-2013/CSA 4.7-2013, Gas fired pool heaters 10

UL 1261 (2001), Standard for electric water heaters for pools and tubs 11

UL 1995 (2011), Standard for heating and cooling equipment 12

ANSI/NFPA 54/ANSI Z223.1 2012, National Fuel Gas Code 13

ANSI/NFPA 58 2014, Liquefied Petroleum Gas Code 14

ASME A112.1.2 (2012), Air gaps in plumbing systems 15

ANSI/APSP-11 2009 Standard for Water Quality in Public Pools and Spas 16

ANSI Z535 series for safety signs and colors (5 standards) (2011) 17

ASTM F2208-08, Standard specification for pool alarms 18

ASTM 1346-91(2010), Standard performance specification for safety covers and labeling requirements for all covers for swimming pools, spas, and hot tubs 19

- 1 U.S. Architectural and Transportation Barriers Compliance Board, 1331 F Street, NW, Suite 1000, Washington, DC 20004, (202) 272-0080, www.access-board.gov
- 2 American Concrete Institute, 38800 Country Club Drive, Farmington Hills, MI 48331, (248) 848-3800, www.concrete.org
- 3, 7, 8, The Association of Pool and Spa Professionals, 2111 Eisenhower Avenue, Alexandria, VA 22314, (703) 838-0083, www.APSP.org
- 4, 5, NSF International, 789 N. Dixboro Rd., Ann Arbor, MI 48113 (734) 769-8010, www.nsf.org
6. The Association of Electrical Equipment and Medical Imaging Manufacturers (NEMA), 1300 N. 17th Street, Suite 1847, Rosslyn, VA 22209 (703) 841-3200, www.nema.org
- 9, 13, National Fire Protection Association (NFPA), 1 Batterymarch Park, Quincy, MA 02269 (617) 770-3000, www.nfpa.org
14. American National Standards Institute (ANSI), 25 West 43rd Street, New York, NY 10036, NY (212) 642-4900, www.ansi.org
- 10, 17. Underwriters Laboratories (UL), 333 Pfingsten Road, Northbrook, IL 60062, (847) 272-8800, www.ul.com
- 11, 12. American Society of Mechanical Engineers (ASME), 3 Park Avenue, 20th Floor, New York, NY 10016, (212) 591-8562, www.asme.org
15. ASTM International, 100 Barr Harbor Drive, W. Conshohocken, PA 19428, (610) 832-9585, www.astm.org
- 18, 19.

3 Definitions

Public swimming pools are classified as follows for purposes of reference and application of this standard:

Class A pools: Class A pools are pool intended for use for accredited competitive aquatic events such as Fédération Internationale de Natation (FINA), USA Swimming, USA Diving, USA Synchronized Swimming, USA Water Polo, National Collegiate Athletic Association (NCAA), National Federation of State High School Associations (NFHS), etc. The pool may also be used for recreation. Class A pools are covered unless otherwise noted in the body of the standard.

Class B pools: Class B pools are pools intended for public recreational swimming not otherwise classified. Class B pools are covered within the scope of this standard.

Class C pools: Class C pools are pools intended for use for apartments, condominiums, property owners associations, multi-family owned pools, etc. and are covered within the scope of this standard. Pools operated solely for and in conjunction with lodgings such as hotels and motels are also covered within the scope of this standard.

Class D pools: Class D pools are *not* covered within the scope of this standard. Class D pools are operated for special purposes, including but not limited to wave action pools, activity pools, leisure rivers, vortex pools, and sand bottom pools.

Class E pools: Class E pools are pools used for physical therapy and are above 86 °F (30 °C) and are *not* covered within the scope of this standard.

Class F pools: Class F pools are wading pools and are covered within the scope of this standard as set forth in Sections 6.9 and 8.4.2, and as noted in other sections of this standard.

remodel: To install cosmetic changes, accessory add-ons, alterations, or modernizations to a commercial installation.

See Renovate.

renovate: To restore or repair all or part of a pool structure and/or its component parts, including the rebuilding and/or replacing of worn or broken parts. *See Remodel.*

slip-resisting: A surface that has been so treated or constructed to significantly reduce the chance of a user slipping. The surface shall not be an abrasion hazard.

4 Code compliance

4.1 Codes. Pools covered by this standard shall be constructed and operated to comply with all local, state, and federal codes governing safety and environmental regulations.

5 General design

5.1 Plans and permits. Prior to construction, remodeling, or renovation of a permanently installed public swimming pool, plans and specifications shall be submitted to the authority (state or local) for review, approval, and issuance of a permit to construct, remodel, or renovate as required by the authority having jurisdiction.

5.2 Materials. Swimming pools and all appurtenances thereto shall be constructed of materials that are nontoxic to humans and the environment; that are generally or commonly regarded to be impervious and enduring; that will withstand the design stresses; and that will provide a watertight structure with a smooth and easily cleanable surface without cracks or joints, (excluding structural joints), or to which a smooth, easily cleanable surface/finish is applied or attached.

5.2.1 Use of sand. Clean sand or similar material, if used in a beach or pool environment, shall be used only over an impervious surface. The sand area shall be designed and controlled so that the circulation system, maintenance, safety, sanitation, and operation of the overall pool are not adversely affected.

5.3 Structural design. The structural design shall be in accordance with accepted engineering practices.

5.4 Freeze protection. In climates subject to freezing temperatures, the pool shell and appurtenances, piping, filter system, pump and motor, and other components shall be designed and constructed to facilitate protection from damage due to freezing.

5.5 Surface condition. The surfaces within the pool intended to provide footing for users shall have a slip-resisting surface and shall not cause injury to the feet during normal use.

5.6 Colors and finishes. The colors, patterns, or finishes of the pool interior shall not obscure objects or surfaces within the pool.

5.7 Accessibility for persons with disabilities. For Americans with Disabilities Act (ADA) requirements for accessibility for persons with disabilities into public swimming pools, see ADA Accessibility guidelines for buildings and facilities, recreation facilities (ADAAG).

NOTE: For ADA requirements, see U.S. ADA Accessibility guidelines (ADAAG). (For more information on the U.S. Department of Justice Americans with Disabilities Act, visit the ADA web site at www.ada.gov. Some pools may be exempt from ADA. See ADA definition of public accommodation for Title II and (Title III facilities).

6 Dimensional design

6.1 Perimeter shape. This standard is not intended to regulate the perimeter shape of swimming pools. It is the designer's responsibility to take into account the effect a given shape will have on the safety of the occupants and required circulation to ensure sanitation. All other dimensions, unless otherwise specified should allow a ± 2 in. (51 mm) tolerance.

6.1.1 There shall be no protrusions, extensions, and means of entanglement, or other obstructions in the swimming pool areas that may cause the entrapment or injury of the user.

6.2 Allowable construction tolerances. Finished pool dimensions shall be held within the following construction tolerances as shown in Table 6.2.

Design Requirements	Construction Tolerance Allowed
Length – overall	± 3 in. (± 76 mm)
Width – overall	± 3 in. (± 76 mm)
Depth – deep area	± 3 in. (± 76 mm)
Depth – shallow area	± 2 in. (± 51 mm)
Step treads & risers	$\pm 1/2$ in. (± 13 mm)
Waterline – pools with adjustable weir skimmers	$\pm 1/4$ in. (± 6 mm)
Waterline – pools with non-adjustable skimming systems (gutters)	$\pm 1/8$ in. (± 3 mm)
All dimensions not otherwise specified in this standard	± 2 in. (± 51 mm)
Competitive pools – Class A pools – All dimensional requirements	As governed by authority having jurisdiction

6.2 These construction tolerances are not applicable to Class A pools.

6.2.2 Diving Envelope. Negative construction tolerances shall not be applied to the shallow dimensions of the Minimum Diving Envelope in Table 6.2.2.

6.3 Floor slope. Floor slopes shall be in compliance with 6.3.1 through 6.3.5, except the requirements by the ADA Accessibility Guidelines (ADAAG).

6.3.1 All pool floors shall be sloped to the drain

6.3.2 The slope of the floor in the shallow area shall not exceed 1 ft in 10 ft in Class C pools or 1 ft in 12 ft ($1:12$) in Class B pools in any direction to the point of the first slope change, if a slope change exists.

6.3.3 The point of the first slope change shall be defined as the point at which the floor slope exceeds 1 ft in 10 ft ($1:10$) in Class C pools or 1 ft in 12 ft ($1:12$) in Class B pools.

6.3.4 The slope of the floor from the point of the first slope change to the deep area shall not exceed 1 ft in 3 ft ($1:3$).

Figure 6.2.2: Construction dimensions for water envelopes for Class B and C pools

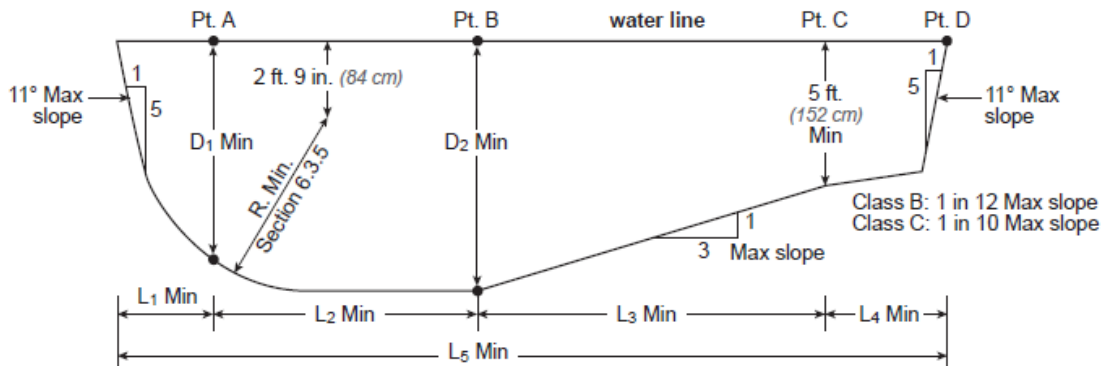

Pool Type	Minimum Dimensions								Minimum Width of Pool at:		
	D1	D2	R	L1	L2	L3	L4	L5	Pt. A	Pt. B	Pt. C
VI	7' - 0" (213 cm)	8' - 6" (259 cm)	5' - 6" (168 cm)	2' - 6" (76 cm)	8' - 0" (244 cm)	10' - 6" (320 cm)	7' - 0" (213 cm)	28' - 0" (853 cm)	16' - 0" (488 cm)	18' - 0" (549 cm)	18' - 0" (549 cm)
VII	7' - 6" (229 cm)	9' - 0" (274 cm)	6' - 0" (183 cm)	3' - 0" (91 cm)	9' - 0" (274 cm)	12' - 0" (366 cm)	4' - 0" (122 cm)	28' - 0" (853 cm)	18' - 0" (549 cm)	20' - 0" (610 cm)	20' - 0" (610 cm)
VIII	8' - 6" (259 cm)	10' - 0" (305 cm)	7' - 0" (213 cm)	4' - 0" (122 cm)	10' - 0" (305 cm)	15' - 0" (457 cm)	2' - 0" (610 cm)	31' - 0" (945 cm)	20' - 0" (610 cm)	22' - 0" (671 cm)	22' - 0" (671 cm)
IX	11' - 0" (335 cm)	12' - 0" (366 cm)	8' - 6" (259 cm)	6' - 0" (183 cm)	10' - 6" (320 cm)	21' - 0" (640 cm)	0' - 0" (0 cm)	37' - 6" (11.4 m)	22' - 0" (671 cm)	24' - 0" (732 cm)	24' - 0" (732 cm)

Note 1: Negative tolerances (see Section 6.2) shall not be applied to any to the dimensions shown in this table.

Note 2: Pool types dictate the minimum water envelope dimensions as specified by the diving board manufacturers.

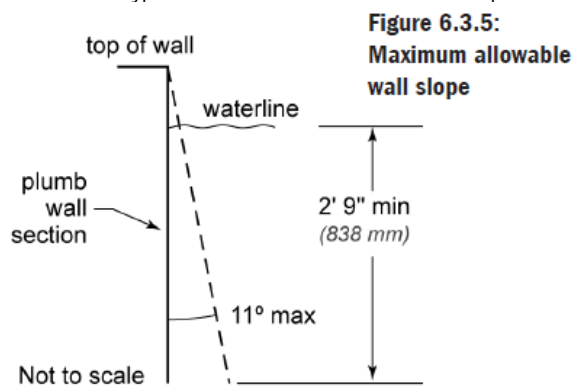

6.3.5 Walls. Where walls join the floor the transitional point or profile shall comply with the following:

Except for Class A pool walls where racing lanes terminate, walls may slope a maximum of 11° from plumb (see Figure 6.3.5).

– Walls may intersect with the floor at an angle or transition profile

– At water depths between 3 ft to 5 ft (91 to 152 cm) the maximum radius shall be 2 ft 3 in. (69 cm).

- At water depths of 3 ft (91 cm) or less, a transitional radius shall not exceed 6 in. (15 cm) and shall be tangent to the wall and may be tangent to or intersecting the floor
- At water depths greater than 3 ft (91 cm), a transitional radius shall be tangent to the wall at a point no less than 2 ft 6 in. (76 cm) below the water surface and may progressively increase from 6 in. (15 cm) to a value capable of being tangent to, or intersecting, the floor

6.4 Water depths. Water depths for swimming areas shall be a minimum depth of 3 ft (91 cm) unless the authority having jurisdiction specifies otherwise.

6.4.1 Class A pools shall be designed and constructed to provide the dimensions specified by Fédération Internationale de Natation (FINA), USA Swimming, USA Diving, USA Synchronized Swimming, USA Water Polo, NCAA, NFHS, or other appropriate sanctioning body.

6.5 Diving. This standard does **not** cover diving requirements for Class A pools. This standard covers diving requirements for Class B and Class C pools.

6.5.1 When manufactured or field fabricated diving equipment is installed, it shall conform to the specifications set forth in Sections 7.2.1 through 7.2.5.6. It shall be located in the deep area of the pool to provide at least the minimum dimensions as shown in Table 6.2.2 and shall be

installed in accordance with the manufacturer’s instructions.

6.6 Manufactured diving equipment installation and use instructions shall be provided by the diving equipment manufacturer, and shall specify the minimum water dimensions required for each diving board and diving stand combination. They shall refer to the diving envelope type of their choice by dimensionally relating their product to Point A on the diving envelopes as shown in *Figure 6.2.2*, *Table 6.2.2*, and Sections 6.6–6.6.1.2.

6.6.1 Point A. Point A is the point from which all dimensions of width, length, and depth are established for the Minimum Diving Water Envelope (see *Figure 6.2.2* and *Table 6.2.2*). If the tip of the diving board or diving platform overhang is located at a distance of Point A or greater from the deep end wall, and the water depth at that location is equal to or greater than the water depth requirement at Point A, then the point on the water surface at the design water level directly below the center of the tip of the diving board or diving platform shall be designated as Point A.

6.6.1.1 Location of point A. The Minimum Diving Water Envelope dimensions for pools with manufactured diving equipment shall be taken from Point A as shown in *Figure 6.2.2*. Point A shall be defined as the point on the water surface at the design water level where the water depth is required at Point A and is provided at a distance of Point A as shown in *Figure 6.2.2* and *Table 6.2.2* from the deep end wall. The center of the tip of the diving board or platform, manufactured or field fabricated, shall be located directly above Point A.

6.6.1.2 Point A, as shown in *Figure 6.2.2* and *Table 6.2.2*, shall be the reference point of origin for all dimensions defining the minimum diving envelope.

6.6.2 Location of equipment and pool features in the minimum diving envelope. If the pool is designed for use with diving equipment, all steps, pool stairs, ladders, underwater benches, offset ledges, special features,

and other accessory items, or any parts thereof, shall be located outside the Minimum Diving Envelope (see *Figure 6.3.5*).

6.7 Rest ledges. Rest ledges along the pool walls are permitted. They shall not be less than 4 ft (122 cm) below the water surface. If a ledge is provided it shall be at least 4 in. (10 cm) wide and no more than 6 in. (15 cm) wide.

6.8 Maximum user load. The maximum user load of Class B or Class C pools shall be in accordance with *Table 6.8*.

6.9 Wading pools. A wading pool shall be a separate pool with an independent circulation system and physically separated from the main pool as described in Sections 6.9.1 through 6.9.5.

Table 6.8: Maximum User Load

Pool/Deck Area	Shallow Instructional or Wading Areas	Deep Area (not including diving are)	Diving Area (per each diving board)
Pools with minimum deck area (see 7.1.6-7.1.6.1.)	15 sq ft. per user (1.35 m ² per user)	20 sq ft. per user (1.8 m ² per user)	300 sq ft. per user (27 m ² per user)
Pools with deck area at least equal to water surface area	12 sq ft. per user (1.08 m ² per user)	15 sq ft. per user (1.35 m ² per user)	300 sq ft. per user (27 m ² per user)
Pools with deck area at least twice the water surface area	8 sq ft. per user (0.72 m ² per user)	10 sq ft. per user (0.9 m ² per user)	300 sq ft. per user (27 m ² per user)

6.9.1 Areas where the water depth at the edge of the pool exceeds 9 in. (23 cm) shall be considered non-entry areas and must be protected by natural or artificial barriers.

6.9.2 Floors of wading pools shall be uniform and sloped to drains, if existing with a maximum slope of 1 ft in 12 ft (1:12).

6.9.3 The maximum water depth shall be 18 in. (457 mm).

6.9.4 The maximum distance from the top of the deck to the water line shall not exceed 6 in. (15 cm).

6.9.5 Suction entrapment avoidance methods for wading pools shall be in accordance with ANSI/APSP/ICC-7.

Exception: Suction outlets are prohibited in wading pools.

7 Decks and deck equipment

7.1 Decks shall comply with Sections 7.1.1 through 7.1.17, as applicable.

7.1.1 Deck(s) shall be designed and installed in accordance with the engineering methods required by the authority having jurisdiction.

7.1.1.1 In the absence of specific local requirements a concrete deck shall be designed and constructed in accordance with the recommended practices of the latest published edition of American Concrete Institute (ACI) *Standard 302.1r-2004, Guide for Concrete Floor and Slab Construction*, or in accordance with the requirements of the local authority, the authority having jurisdiction, or both. The deck shall be designed and constructed to meet the applicable requirements of the Americans with Disabilities Act.

7.1.2 Decks, ramps, coping, and similar step surfaces shall be slip-resisting and cleanable.

7.1.3 Special features in or on deck(s) such as markers, brand insignias, or similar materials shall be slip-resisting.

7.1.4 Step risers for the deck shall be uniform and have a minimum height of 3-3/4 in. (9.5 cm) and a maximum height of 7-1/2 in. (19 cm). A handrail shall be provided for stairs having three or more risers. The minimum tread distance from front to back shall be 11 in. (28 cm).

7.1.5 The deck or unobstructed access shall be provided at a minimum of 65% of the pool perimeter to meet the requirement of the 10/20 rule.

NOTE: The 10/20 rule states that a qualified lifeguard or a number of lifeguards shall be trained and stationed in a manner that will permit them to identify an incident or trauma within ten (10) seconds of its initiation. Upon identification of the incident or trauma, the guard shall be able to respond to and initiate indicated protocol appropriate to the circumstance within twenty (20) additional seconds.

7.1.5.1 A minimum 4 ft (122 cm) deck width shall be provided on the sides and rear of any diving equipment, including diving boards, jump boards, diving rocks, platforms, starting blocks. A deck clearance of 3 ft (91 cm) shall be provided around all other deck equipment.

7.1.6 The minimum slope of the deck(s) shall be 1/8 in. per ft (1: 96) for textured, hand-finished concrete decks; 1/4 in. per ft (1: 48) for exposed aggregate concrete decks; 1/2 in. per 1 ft (1: 24) for indoor/outdoor carpeting decks; and 3/8 in. per ft (1: 32) for brick and heavy textured finishes, unless an alternate drainage method is provided that prevents the accumulation of pooling of water (see *Table 7.1.6*).

7.1.6.1 Decks shall be sloped so that standing water shall be no deeper than 1/8 in. (3 mm), 20 minutes after the cessation of the addition of water to the deck.

NOTE: Two stacked U.S. quarters can be used to measure the depth. Water should not cover the quarters.

Surface	Minimum drainage slope
Textured, hand-finished concrete	1/8 in./ft (1: 96)
Exposed aggregate	1/4 in./ft (1: 48)
Carpet	1/2 in./ft (1: 24)
Brick and heavy textures, finished	3/8 in./ft (1: 32)

7.1.7 The maximum slope of all decks, other than wood decks, shall be 1/2 in. per ft (1: 24) except for ramps.

7.1.7.1 The maximum slope for wood decks shall be 1/8 in. per ft (1: 96).

7.1.7.2 Gaps shall be required between deck boards in wood decks, and shall be consistent with approved engineering methods with respect to the type of wood used. They shall not cause a tripping hazard.

7.1.8 The maximum open gap between pool decks and adjoining decks or walkways, including joint material, shall be 3/4 in. (19 mm). The difference in vertical elevation between the pool deck and the adjoining sidewalk shall be 1/4 in. (6 mm) unless it conforms to Section 7.1.4.

7.1.9 Construction joints where the pool coping meets the concrete deck(s) shall be watertight.

7.1.10 Construction joints where the pool coping meets the concrete deck(s) shall be installed to protect the coping and its mortar bed from damage as a result of the anticipated movement of adjoining deck(s).

7.1.11 Control joints in deck(s) shall be provided to minimize visible cracks outside the control joints due to imposed stresses and/or movement of the slab.

7.1.12 Areas where decks join existing concrete work shall be protected by an expansion joint to protect the pool from the pressures of relative movements.

7.1.13 The edges of all decks shall be radiused, tapered, or otherwise designed to eliminate sharp corners.

7.1.14 Pressure tests. The pressure testing of the pool piping shall be maintained throughout the pool's construction and in accordance with Section 8.4.

7.1.15 Valves installed in or under any deck(s) shall have access provided for operation, service, and maintenance. Access covers shall be provided.

7.1.16 Hose bibb(s), with a cross connection control to prevent backflow, shall be provided for rinsing down the entire deck and shall be in accordance with the authority having jurisdiction.

7.1.17 Water-powered devices (such as water-powered lifts) shall have a dedicated hose bib (water source) with approved backflow protection in accordance with the authority having jurisdiction.

7.2 Deck equipment. Deck equipment including diving facilities and starting blocks shall comply with Sections 7.2.1 through 7.4, as applicable.

7.2.1 A minimum 4 ft (122 cm) deck width shall be provided on the sides and rear of any diving equipment, including diving boards, jump boards, diving rocks, platforms, starting blocks.

7.2.2 Starting blocks. Starting blocks are intended for competitive swimming and shall conform to Fédération Internationale de Natation (FINA), USA Swimming, National Collegiate Athletic Association (NCAA), or National Federation of State High Schools Associations (NFHS) regulations.

7.2.3 The diving equipment manufacturer shall specify minimum head room required above the tip of the board.

7.2.4 Public pools with diving equipment of 1 meter (39.4 in.) or greater in height, or pools designed for springboard or platform diving, shall comply with the dimensional design requirements of Fédération Internationale de Natation (FINA), USA Diving, National Collegiate Athletic Association (NCAA), National Federation of State High Schools Association (NFHS) or the appropriate sanctioning body.

7.2.5 Diving equipment. Diving equipment shall be installed in accordance with the manufacturer's specifications.

7.2.5.1 The diving equipment manufacturer shall affix a label to the diving equipment.

7.2.5.2 A label shall be permanently affixed to and visibly located on the diving equipment or jump board and shall include but not be limited to the following:

- The minimum water envelope required for each diving board and diving stand combination.
- Manufacturer's name and address.
- Manufacturer's identification and date of manufacture, and
- The maximum weight of the user.

7.2.5.3 The diving equipment manufacturer shall provide diving equipment use instructions.

7.2.5.4 Diving equipment shall have slip-resisting tread surfaces.

7.2.5.5 Supports for diving equipment. Supports, platforms, stairs, and ladders for diving equipment shall be designed to carry the anticipated loads. Stairs and ladders shall be of corrosion-resisting material and shall be easily cleanable and with slip-resisting tread. All diving stands higher than 21 in. (53 cm) measured from the deck to the top back end of the board shall be provided with stairs and/or a ladder. Step treads shall be self-draining.

7.2.5.6 Diving equipment 1 meter (39.4 in.) high or higher shall be provided with a top guard rail, which shall be at least 30 in. (76 cm) above the diving board, and extend to above the edge of the pool wall.

7.2.5.7 Springboard fall protection guards. Springboards located at a height greater than 5 ft (1.5 m) above the pool deck shall have a fall protection guard on each side of the springboard. The design and the selection of the materials of construction of such fall protection guards shall be determined by the manufacturer of the springboard support structure. The installation and maintenance of such fall protection guards shall be in accordance with the fall protection guard manufacturer's instructions.

7.3 Swimming pool slides. Swimming pool slides, when installed, shall comply with the requirements of the U.S. Consumer Product Safety Commission (CPSC) as published in the *Code of Federal Regulations*, 16 CFR, Part 1207. The manufacturer shall provide installation and use instructions with each slide. Each slide shall be installed in accordance with the manufacturer's instructions.

7.4 Play/water activity equipment. When installed, play/water activity equipment shall be installed in accordance with manufacturer's instructions.

For a copy of the complete ANSI/APSP/ICC-1 2014 American National Standard for Commercial Inground Swimming Pools contact:

The Association of Pool and Spa Professionals (APSP)
2111 Eisenhower Avenue
Suite 500
Alexandria, VA 22314-4695
Phone: (703) 838-0083
Fax: (703) 549-0493
www.apsp.org