

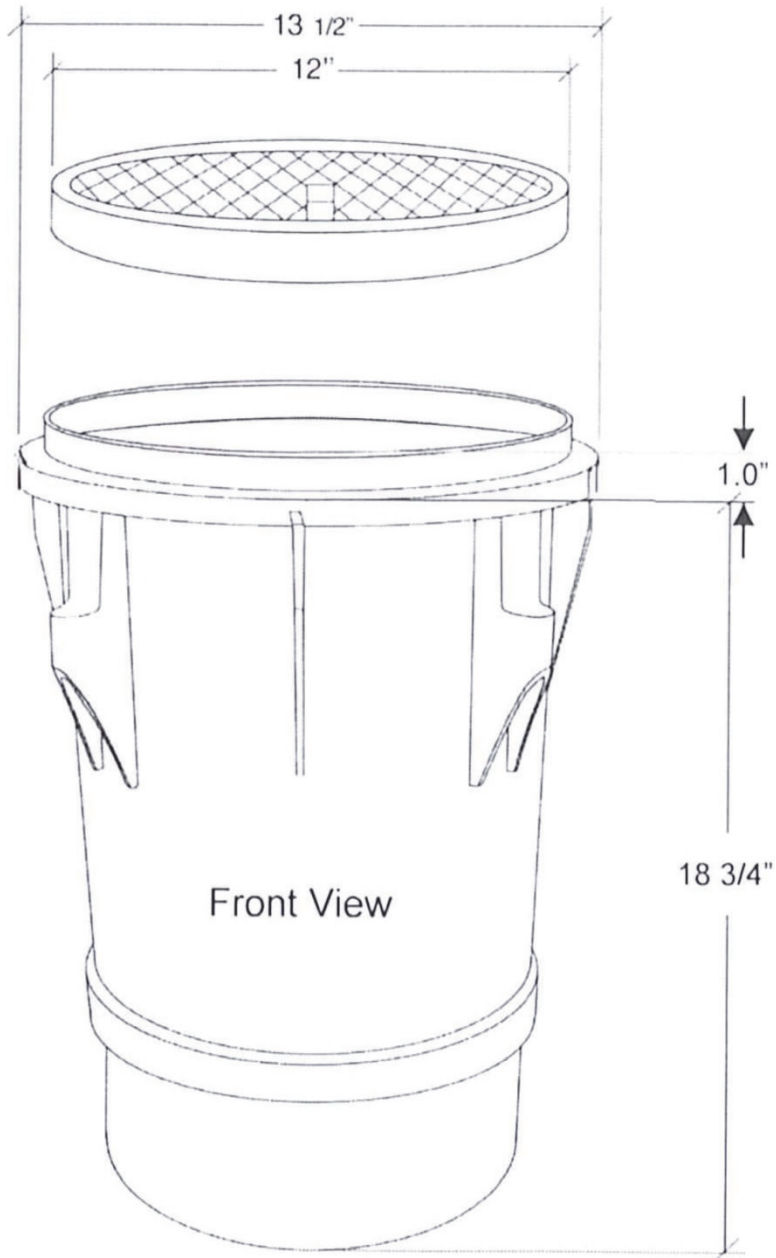

**Color Light Streams™ Large Laminar  
Installation Manual  
(CLSLL)**



Input Power: 12V AC  
Total Power: 5W



**ETL listed for installations within 5 ft. (1.5M) of outer edge of water**



## SAVE THESE INSTRUCTIONS!

These directions are provided to ensure the proper installation and operation of S.R. Smith Color Light Streams™ Large Laminar. The maximum lighted distance of the laminar stream should be considered 6ft height and 6ft in distance. If the laminar arc is over 6ft there is a high degree of probability that the lighting will not travel the full distance to the bottom of the laminar flow. Also, if the throw distance is over 6ft, the lighting will also fail to go the full distance of the laminar stream.

### **IMPORTANT:**

***Read and follow all safety and installation instructions carefully before installation.***

The product must be installed in accordance with the applicable installation code by a person familiar with the construction and operation of the product and hazard involved.

### **IMPORTANT GENERAL SPECIFICATIONS:**

1. **The water supply to the Color Light Streams Laminar fountains *must* be filtered with a cartridge filter.** Sand filter and DE filters will likely produce small particles of debris that will clog the filter screens internal to the laminar flow fountains.
2. Water supply is dependent upon 3 important factors:
  - a. Pump size – if dedicated pump is used it must be a minimum of a ½ hp and supply proper flow rate at 16 ft of head.
  - b. Plumbing pipe size
  - c. Number of laminar flow fountains on system

**NOTE: GENERAL RULE OF THUMB IS THAT EACH LAMINAR FOUNTAIN REQUIRES APPROXIMATELY 10 GPM.  
SEE FOLLOWING SECTION ON DESIGN CRITERIA**

**THE LAMINAR FLOW DECK BOX IS MADE OF ABS MATERIAL. USE ONLY ABS-PVC GLUE WHEN MAKING ANY CONDUIT CONNECTIONS TO THIS DECK BOX**

3. Each S.R. Smith Color Light Streams Large Laminar flow fountain requires 12VAC. **Minimum sized conduit is 3/4"**. Run the supplied 100ft of 12VAC wire from the Color Light Stream LED driver through the conduit back to the location of your transformer (not included).
4. S.R. Smith Color Light Streams Large Laminar flow fountains can be placed in most any location from concrete decks, raised bond beams or even softscapes. Be sure that the distance from the interior pool wall to the laminar flow fountain is no further than 5'. This would allow the lighted laminar flow stream to be 1' into the pool interior.



5. Each fountain requires a 1" (see table on page 5 for pipe size progression) PVC water supply that will be glued to the supplied reducer that connects the PVC flex inlet hose.
6. Each laminar may also have an individual, optional gate valve installed for minor flow adjustments. All main flow gate valves should be located as close as possible to the equipment pad area to reduce water turbulence from entering the laminar fountain.
7. On main water supply line install a cartridge filter and check valve.
8. Bypass line and main flow gate valve needs to be installed.
9. A plumbing loop is highly recommended for multiple fountain installations.

#### **INSTALLATION OF THE LAMINAR FLOW DECK BOX**

1. Reconfirm that fountain is no further than 5 feet away from the interior water surface of the pool.
2. Prepare location by digging hole approx. 24" in diameter and 30" deep.
  - a. For 'in-deck' applications – Level the lid to the finished grade level of decking.
  - b. For planter areas – Laminar lid should be 2 inches ABOVE the landscape area to prevent materials from intruding or washing into the fountain itself.
3. Remove the laminar flow fountain from the deck box assembly by unscrewing the hose union connection on the  $\frac{3}{4}$ " flex inlet hose. Please note the number of rotations required to wrap the hose inside the deck box and DO NOT shorten the hose.
4. Use the provided union cap on the water line source side of the hose for pressure testing and winterization. DO NOT LOSE.
5. Place the deck box into the excavated hole on the center stand pipe or rebar sockets on the side of the deck box with the drain line hole in-line with the direction of the desired water flow (towards pool interior). This will place the water connection at the very rear of the Laminar, opposite of the pool wall. Please note that the hose now exits the rear of the deck box at a 45 degree left angle as viewed from the back.
6. The bottom of the deck box can be supported by utilizing the 1" PVC support connection. The support pipe should be long enough to support the deck box at the planned level. You may also support the deck box using the new rebar sockets to help maintain the proper level.



7. Install 1" PVC pipe to the drain line connection. ***IT IS IMPERATIVE THAT ALL LAMINAR FLOW FOUNTAINS HAVE PROPER DRAINAGE AND ARE NOT ALLOWED TO FLOOD.*** Failure to provide adequate drainage may prevent proper operation and void warranty.
8. Install 3/4" PVC conduit for 12VAC cable run to either side of the deck box.
9. Glue a 1" PVC Water supply line (*see table on page 5 for pipe size progression*) to the 3/4" PVC flex hose water connection using the attached 1" to 3/4" reducer.
10. Fill excavated area with gravel until gravel reaches approximately 1" up on bottom of deck box.
11. Finish your deck material installation making sure that the Color Light Streams™ Large Laminar flow fountains remain level. Utilizing the Adjustable Deck Flange adjust to match your deck height.

**IT IS EXTREMELY IMPORTANT THAT THE WATER SUPPLY LINE TO EACH LAMINAR IS FLUSHED SO THAT ALL MATERIAL THAT MIGHT BE IN THE LINES ARE REMOVED PRIOR TO BEING REINSTALLED INTO THE LAMINAR FLOW DECK BOX.** *Foreign material and organic matter will affect the performance of the fountain and is very difficult to remove.*

***NEVER START UP LAMINAR FOUNTAINS WITHOUT COMPLETING THIS STEP !!***

12. After the deck box has been installed and system has been pressure tested, the laminar flow fountain itself may be reinstalled.
13. **DO NOT REMOVE** the clear protective film on the deck box lid until after the pool deck has been installed. This is intended to prevent foreign debris from falling into the jet or deck box and damaging / plugging the unit.



**ADJUSTING WATER FLOW**

The laminar arc is determined by two factors: GPM water flow and angle of laminar.

Set the angle of the laminar flow by using the two adjustment knobs on the inside the deck box on either side of the laminar. Adjust your distance by opening or closing each respective gate valve until the desired distance is achieved. **Do not adjust jet with a screw driver or similar tool. scoring of the outlet orifice must be avoided.**

**MAXIMUM HEIGHT AND DISTANCE IS 6' UP / 6' OUT.**

**Initial start up should be done gradually, allowing each laminar to fill with water slowly and allowing air to escape. Failure to do so may cause damage to unit and plumbing. Burping or air pocket purging is part of normal laminar flow fountain operation until all trapped air is released from the entire system (plumbing and laminar jets).**

**DO NOT EXCEED 15 GPM PER LAMINAR OR DAMAGE CAN BE DONE INTERNALLY.**

**Plumbing Chart**

**# of Large Laminars**

	1	2	3	4
<b>GPM</b>	<b>10</b>	<b>20</b>	<b>30</b>	<b>40</b>
<b>Head (FT)</b>	<b>18</b>	<b>21</b>	<b>31</b>	<b>42</b>

**Recommended Pipe Size Chart**

# of Laminar units	Section A	Section B	Section C
1	1.5"	1"	1"
2	1.5"	1.5"	1"
3	2"	1.5"	1"
4	2"	1.5"	1"

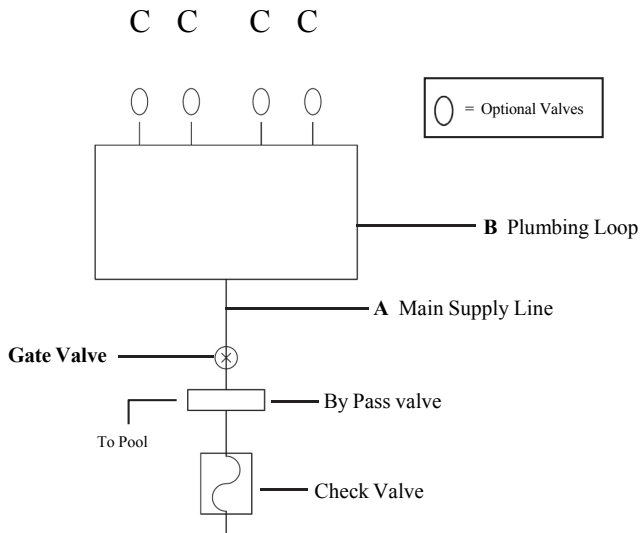



### Basic Operation for LED CLS-2is

Advanced control requires iStar Controller - see operation manual for further instructions

When connected to an approved, 12VAC, Class 2 power supply - The S.R.Smith CLS-2is LED color changing light source uses simple 'off / on' power switching to control the basic, pre-defined color modes with memory function. This allows for a variety of simple control layouts to best fit your application.

### Memory

The new memory function will allow the user to have the same color light as last used. For example, if the light was last used in Blue mode, the next time the light is simply turned on - it will use the memorized color.

### Color Mode Selection

Due to the memory function, when the lights are switched on, they will display the last used color. To move to the next color mode, simply toggle the power to the lights 'OFF / ON' within 1 second or faster.

Advance through the modes until the desired color (mode) is selected - the modes will cycle 1,2,3,4,5,6,7,8, then cycle back to #1 and repeat (see table at bottom of this page).

### Color Sync - Reset

The memory function may make it difficult get all lights to Color Sync depending on how the units are installed and tested. To synchronize all lights on the system including older \*Fiberstars LED Series Pool lights, you must use the following sequence:

1. Turn lights 'ON' to confirm the color modes are out of sync.
2. Turn lights 'OFF' for 5 seconds or more.
3. Toggles lights 'ON' / OFF' three times within three seconds - must end in 'OFF' condition
4. Leave lights in 'OFF' condition for 5 seconds.
5. Turn lights 'ON' and confirm that all lights are in mode #1, Soft Color Change

Color Mode Selection Guide	
Mode 1	Soft Color Change
Mode 2	White
Mode 3	Blue
Mode 4	Green
Mode 5	Red
Mode 6	Amber
Mode 7	Magenta
Mode 8	Flash Color Change

\* Older Fiberstars LED lights can synchronize with the newest generation lights ONLY if they have their DIP switches in their default, 'All Down' position shown below. In a mixed environment, the Color Sync Reset will need to be performed each time the lights are used and color synchronization is desired.

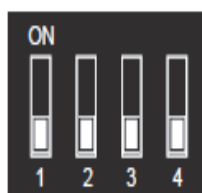



## **IMPORTANT NOTES AND REMINDERS**

Minimize the number of plumbing fittings in the water run to cut down flow restrictions and water turbulence.

Laminar flow fountains are susceptible to wind conditions and the higher the angle of your fountain the more they may be effected. If your area has regular amounts of high winds you may consider moving the fountains closer to the pool edge and decreasing the arc length of the fountain.

For adjustment of S.R. Smith Light Enhancement Device (Scratcher) please see attached direction sheet (last page).



## **Winterization is recommended in areas with freezing conditions.**

### **Winterization steps:**

1. Remove LED light source from jet body by carefully unscrewing it from the threaded adaptor on jet body. Carefully place in a plastic bag and seal. Leaving it inside the deck box in an elevated position will help in case of flooding as it is not to be submerged.
2. Carefully loosen and separate the ¾" union on the water supply line inside the deck box - be careful not to lose any O-ring seals. BLOW WATER LINES CLEAR and use the winterization / pressure test cap to seal the water line.
3. Loosen and remove the adjustment knobs on the side of the jet. Pop the cover caps off being careful to also remove the o-ring seals. Place caps, o-rings, and threaded knobs together in a plastic bag to keep with the jet body once removed for storage.
4. Gently pry one of the mounting arms away from the jet body and roll the jet body out of the mounting arms, the second arm should release easily once the first one is clear.  
***Take care to not damage or scratch the exposed acrylic rod on the bottom of the jet.***
5. Remove jet body and dump remaining water from it by slowly rotating the jet in all directions – **DO NOT DROP**. Water will come out of all four openings at different times and positions. Repeat until all water is removed. Store jet bodies and the attachment hardware together in a safe location.

### **Periodic Maintenance**

If internal components of the Color Light Streams™ Large Laminar become obstructed this will affect the laminar stream or light output. To correct this, please remove the Color Light Stream Laminar fountain from the deck box assembly and apply water pressure at the laminar fountain exit point. This will back flush the laminar and allow some debris to exit through the inlet.

After back flushing, reinstall the Color Light Stream laminar fountain and adjust water flow and angle for desired effect.



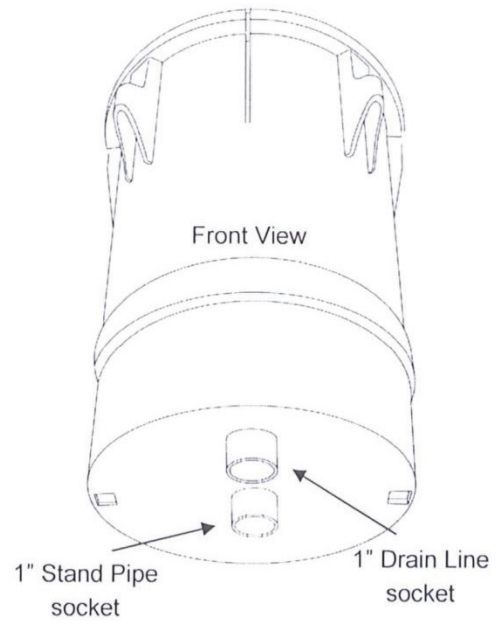
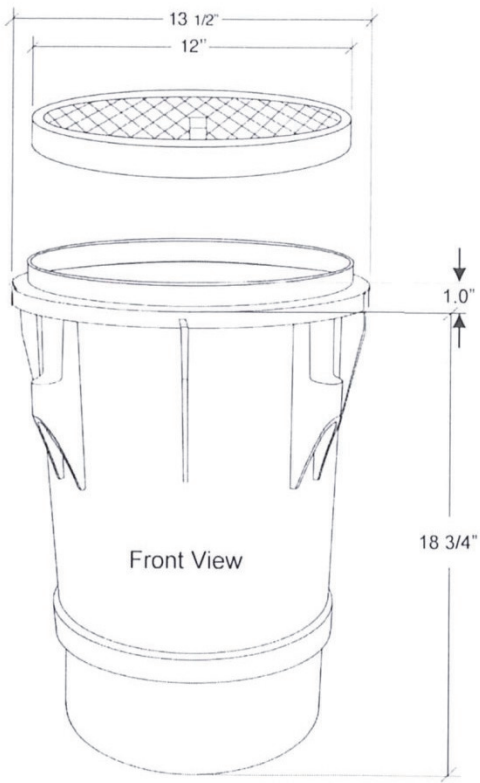
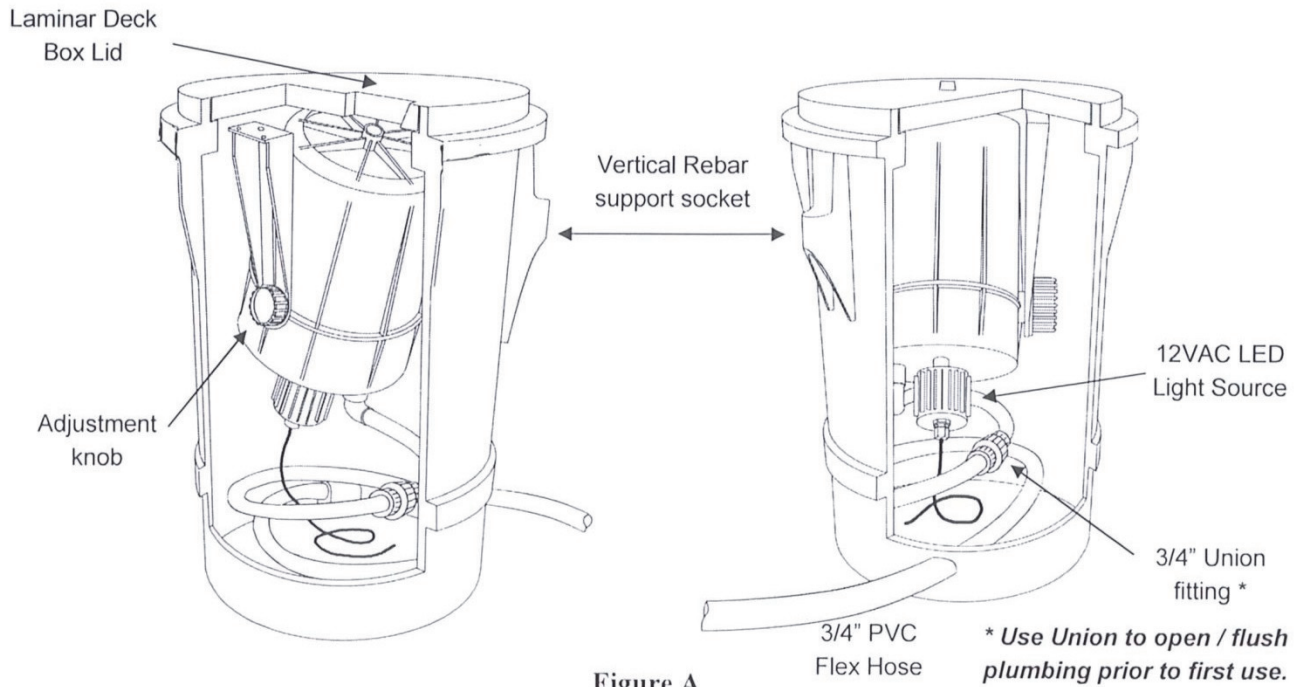

## **Lighted Laminar Light Enhancement Device**

In order to achieve maximum light output, the Light Enhancement Device will need to be adjusted. Adjustment of the “scratcher” or Light Enhancement Device will increase the light output of the laminar flow stream and also will allow you to create water effects such as “pulsing” of the flow stream and light output.

**NOTE: For best effects the following should be done in a dark or night time environment**

### **Adjustment**

1. Ensure that all connections and other installation requirements have been completed.
2. Turn on and operate system as per other directions. This will allow you to adjust the water direction and height properly along with the water flow (GPM) that you wish to achieve.
3. Once both of the above have been completed, turn off system.
4. Raise the laminar flow lid/fountain by the edge of the deck box approximately 4 inches.
5. Insert 1 – 2” x 4” board under each side of the lid, parallel with the slot in the lid, so that the lid is supported, yet raised up from the deck box base.
6. Turn back on the system and reestablish water flow to the fountain.
7. The “scratcher” has 3 adjustment screws. Adjust each screw so that the tip just touches the water flow.  
(See diagram below)

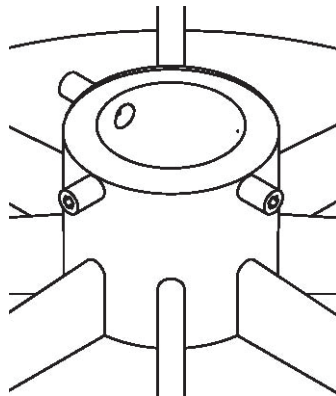

8. As you increase the contact area of each screw you can achieve different light effects, such as color / light streaking or highlights caused by added surface disturbance within the water flow. Please remember that the brighter the light is in the beginning or middle of the stream arc, the less light will be available at the end of the arc where the water lands in the pool.

9. Once you have made the adjustments to achieve your desired effects, add a little drop of silicon or a non permanent thread locking compound on each screw. Turn off the system and remove the 2” x 4” braces and set the laminar/lid back into place on the deck box flange.

10. Turn on the system one last time as a final inspection to insure that the lighting effect you adjusted for in #7 is still there. You may have to do several adjustments to achieve the maximum lighting effect.