

REVISIONS			
REV.	DESCRIPTION	DATE	ECN

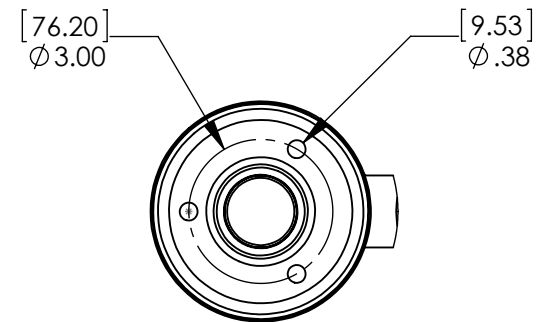

DETAIL B  
SCALE 1 : 4

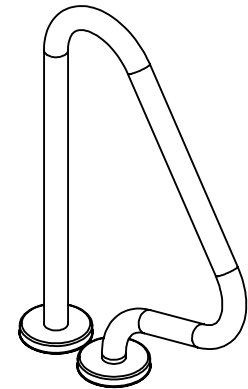
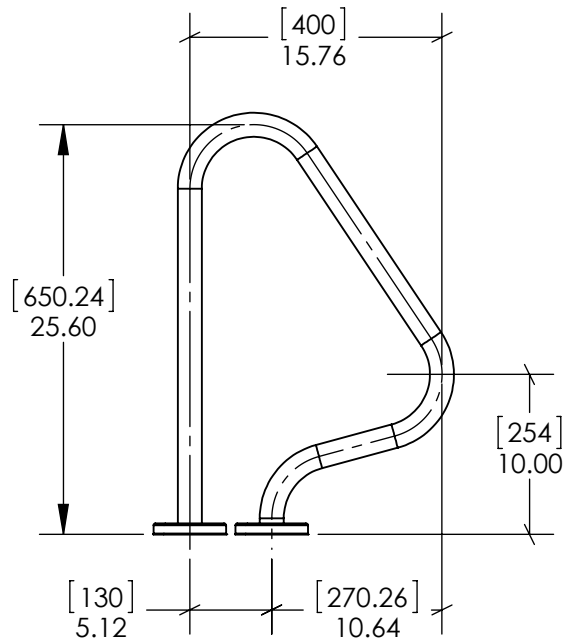
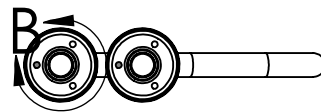

TUBING LENGTH: 64.47"

UNLESS OTHERWISE SPECIFIED  
DIMENSIONS ARE IN INCHES,  
TOLERANCES ARE:  
FRACTIONAL: ..... ±1/16  
ANGULAR: ..... ±1°  
TWO PLACE DECIMAL: .... ±.06  
THREE PLACE DECIMAL: .. ±.031

DESCRIPTION:  
NARROW FIGURE 4 GRAB RAIL -  
FLANGED (PAIR) 38MM X 1.2MM

MATERIAL:  
1.50 x .049 (316L) S/S TUBING

PART NO.: SR-4F REV. A

DRAWN BY: DTJ DATE: 4/1/14

CHECKED BY: DATE:



P.O. BOX 400 - 1017 S.W. BERG PARKWAY  
CANBY, OREGON 97013  
PHONE (503) 266-2231

SIZE: A SCALE: 1:18 SHEET 1 OF 3

REVISIONS			
REV.	DESCRIPTION	DATE	ECN

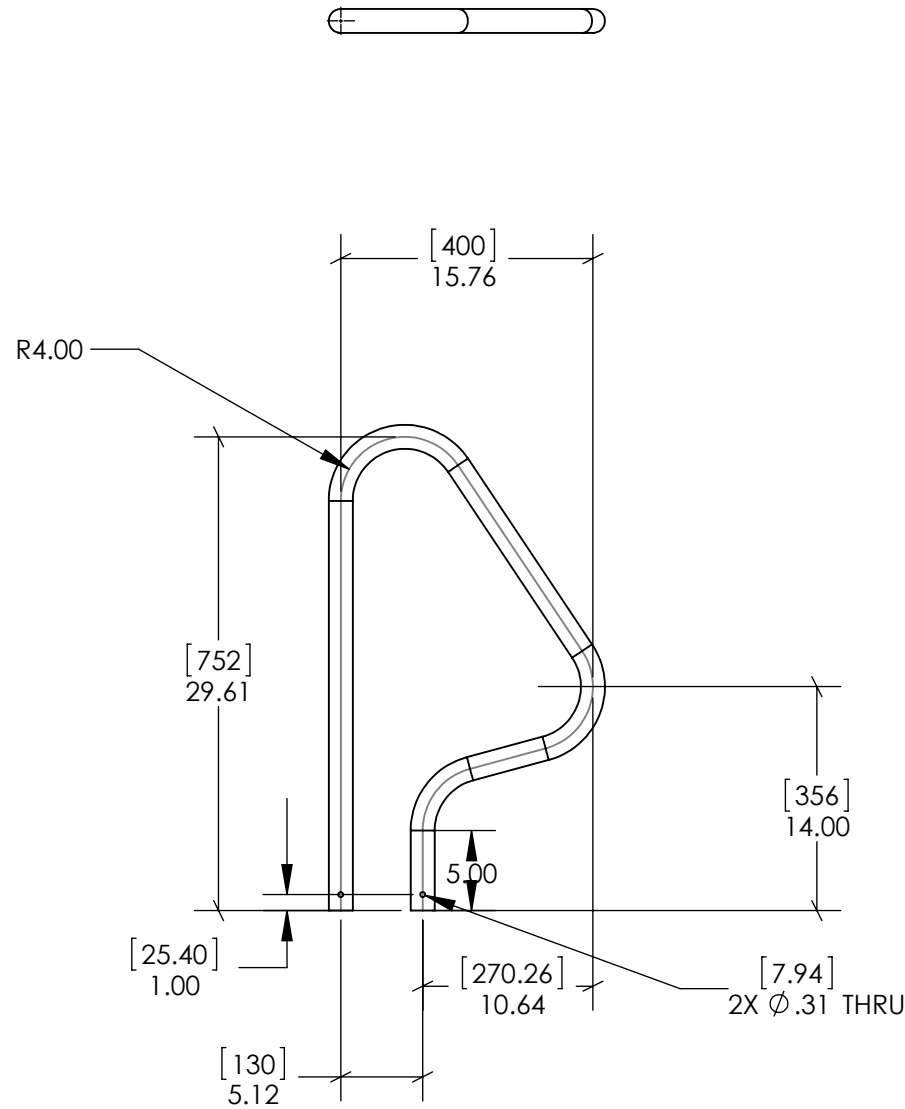

TUBING LENGTH: 72.49"

UNLESS OTHERWISE SPECIFIED  
DIMENSIONS ARE IN INCHES,  
TOLERANCES ARE:  
FRACTIONAL: ..... ±1/16  
ANGULAR: ..... ±1°  
TWO PLACE DECIMAL: .... ±.06  
THREE PLACE DECIMAL: .. ±.031

DESCRIPTION:  
NARROW FIGURE 4 GRAB RAIL -  
STANDARD (PAIR) 38MM X 1.2MM

MATERIAL:  
1.50 x .049 (316L) S/S TUBING

PART NO.: SR-4S REV. A

DRAWN BY: DTJ DATE: 4/1/14

CHECKED BY: DATE:



P.O. BOX 400 - 1017 S.W. BERG PARKWAY  
CANBY, OREGON 97013  
PHONE (503) 266-2231

SIZE: A SCALE: 1:18 SHEET 1 OF 2