

REVISIONS			
REV.	DESCRIPTION	DATE	ECN

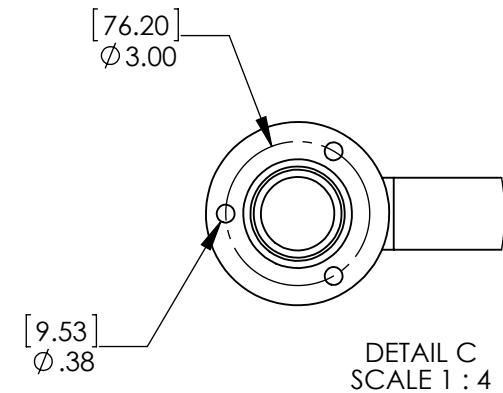
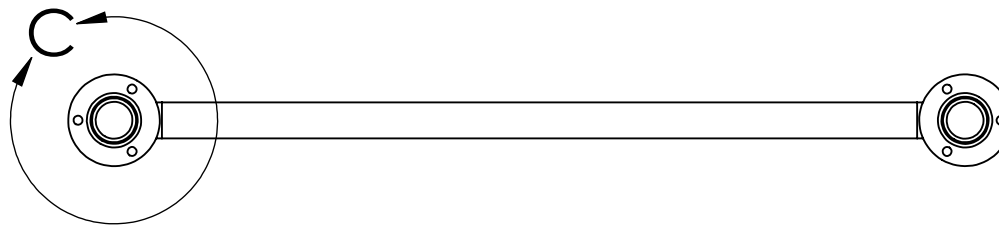
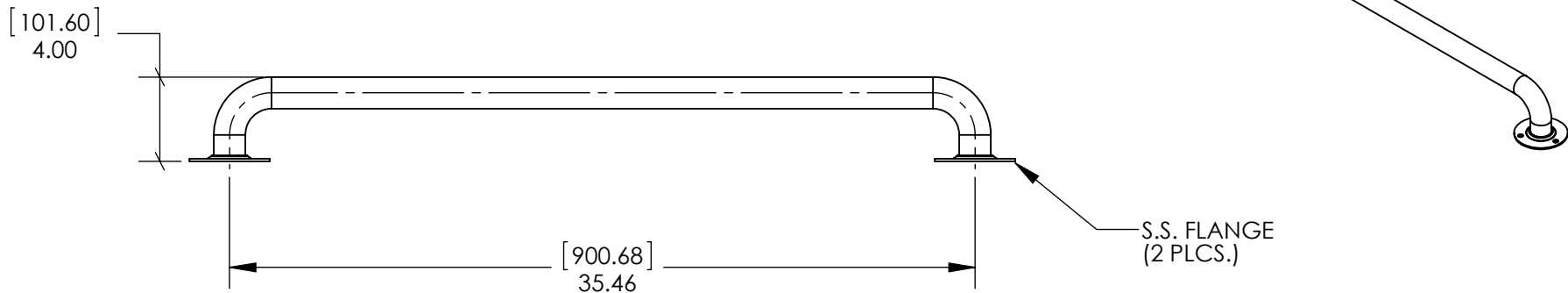

TUBING LENGTH: 39.70"

UNLESS OTHERWISE SPECIFIED
DIMENSIONS ARE IN INCHES,
TOLERANCES ARE:
FRACTIONAL: ±1/16
ANGULAR: ±1°
TWO PLACE DECIMAL: ±.06
THREE PLACE DECIMAL: .. ±.031

DESCRIPTION:
SAFETY RAIL - 900MM FLANGED

MATERIAL:
1.50 x .049 (316L) S/S TUBING

PART NO.: SSR-900 REV. A

DRAWN BY: DTJ DATE: 4/1/14

CHECKED BY: DATE:



P.O. BOX 400 - 1017 S.W. BERG PARKWAY
CANBY, OREGON 97013
PHONE (503) 266-2231

SIZE: A SCALE: 1:8 SHEET 1 OF 3